

Doppelverzahnung Lizenz Traub
double tooth system licence Traub

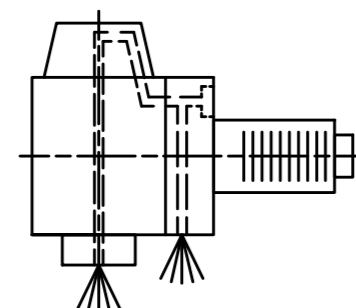

Innen- und Aussenkuehlung / Inside and outside coolant supply
Kein Trockenlauf / No dry run
Kuehlmittelfiltrierung50μ / coolant filtration50μ

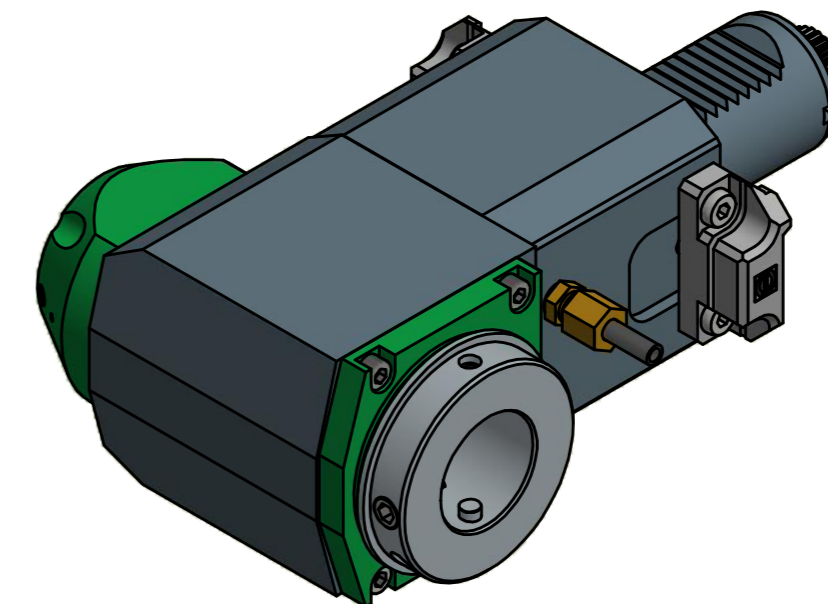

Copyright **EWS Tool Technologies**
Weitergabe und Vervielfaeltigung dieser Unterlage,
Verwertung und Mitteilung ihres Inhalts nicht
gestattet, soweit nicht ausdrecklich zugestanden.
Zuwoerhandlungen verpflichten zu Schadenersatz.

Bemerkung - Note Nicht ohne Kuehlmittel betreiben! Not for use without coolant-fluid!	Technische Daten - technical data Weight = 7.922 [kg]	Benennung - Title
	Torque max. (M1/M2) = 50 / 50 [Nm]	
	Speed max. (n1/n2) = 6000 / 6000 [1/min]	
	Gear ratio (i)=n1:n2 = 1:1	
	Pressure (pmax) = 70 [bar]	

EWS Tool Technologies <small>EWS Weigle GmbH & Co. KG Maybachstr. 1 D-73066 Uhlingen www.ews-tool.de</small>	Technische Aenderungen vorbehalten! Subject to technical modifications! IDENT: DEWS046776	
	Nr. - No. 60.40V4LCTXRLIKTFR	REV: -/A MNR. 201660

