

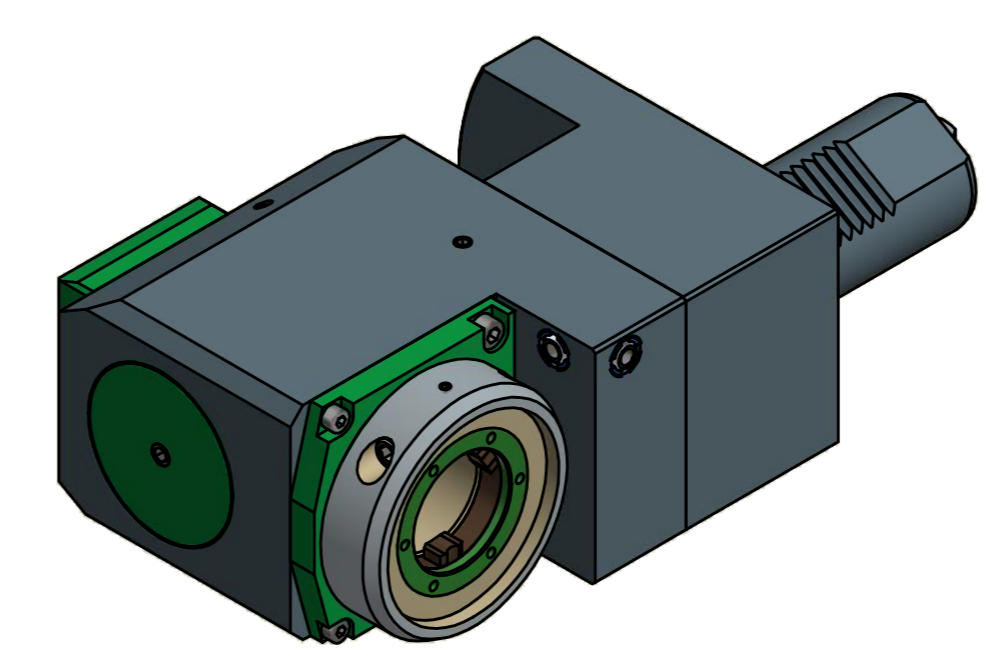



Innen- und Aussenkuehlung / Inside and outside coolant supply
 Kuehlmittefiltrierung=50µ / coolant filtration=50µ

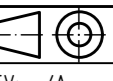

Copyright **EWS Tool Technologies**
 Weitergabe und Vervielfaeltigung dieser Unterlage,
 Verwertung und Mitteilung ihres Inhalts nicht
 gestattet, soweit nicht ausdrecklich zugestanden.
 Zuwiderhandlungen verpflichten zu Schadenersatz.

Bemerkung - Note Für Trockenlauf geeignet! Use without coolant fluid allowed!	Technische Daten - technical data Weight = 3.635 [kg] Torque max. (M1/M2) = 50 / 25 [Nm] Speed max. (n1/n2) = 5000 / 10000 [1/min] Gear ratio (i)=n1:n2 = 1:2 Pressure (pmax) = 70 [bar]	Benennung - Title Radial Bohr und Fräskopf, zurückges Radial drill. and mill. head offset	 EWS Weigle GmbH & Co. KG Maybachstr. 1 D-73066 Uhingen www.ews-tools.de Technische Aenderungen vorbehalten! Subject to technical modifications! IDENT: DEWS001247 Nr. - No. 80.40VX4SQT15RIKD11	 REV: -/A MNR. 197110 
---	---	---	---	---