

Doppelverzahnung Lizenz Traub
double tooth system licence Traub

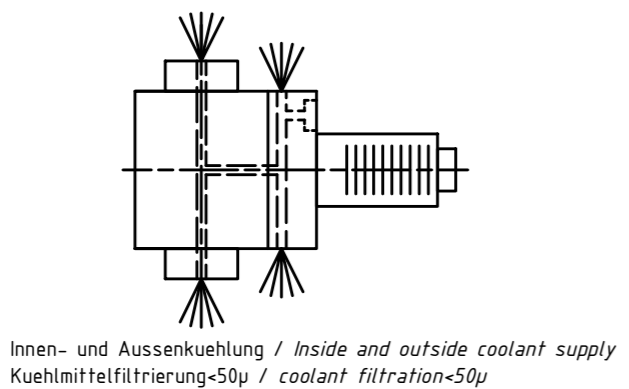

Innen- und Aussenkuehlung / Inside and outside coolant supply
Kuehlmittefiltrierung<50µ / coolant filtration<50µ

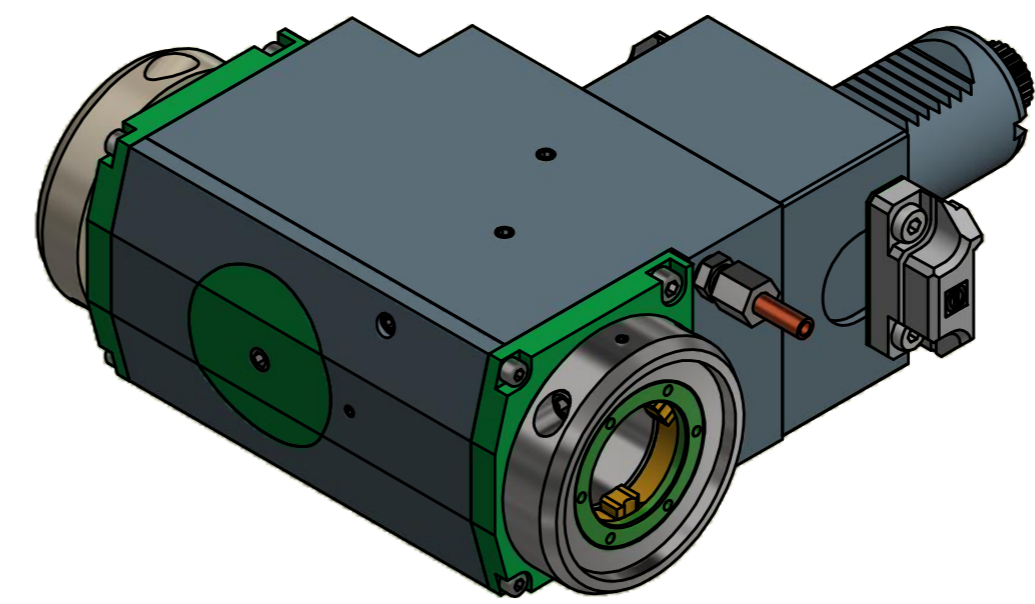

Bemerkung - Note Für Trockenlauf geeignet! Use without coolant fluid allowed!	Technische Daten - technical data Weight = 10.816 [kg]
	Torque max. (M1/M2) = 50 / 25 25 [Nm]
	Speed max. (n1/n2) = 6000 / 12000 12000 [1/min]
	Gear ratio (i)=n1:n2 = 1:2 1:2
	Pressure (pmax) = 70 [bar]

Benennung - Title
 Radial Bohr und Fräskopf, zurückges
 Radial drill. and mill. head offset

EWS <small>EWS Weigle GmbH & Co. KG Maybachstr. 1 D-73066 Uhlingen www.ews-tools.de</small>	Technische Änderungen vorbehalten! Subject to technical modifications! IDENT: DEWS090908	MNR. REV: -/C
	Nr. - No. 80.40VX4LDCTXRLIKD11TFR	196689

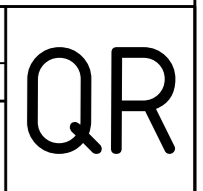

Copyright **EWS Tool Technologies**
 Weitergabe und Vervielfältigung dieser Unterlage,
 Verwertung und Mitteilung ihres Inhalts nicht
 gestattet, soweit nicht ausdrücklich zugestanden.
 Zuwiderhandlungen verpflichten zu Schadenersatz.