

Spannzange / collet ER25 DIN6499  
 Spannbereich / clamping range: 1,0 - 16,0

Gewindebohrzange / tapping collet  
 ET-1-25 M3-M10

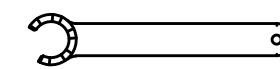

Spannzangenschlüssel für  
 innenliegende Mutter  
 Clamping wrench for  
 internal collet  
 225AX

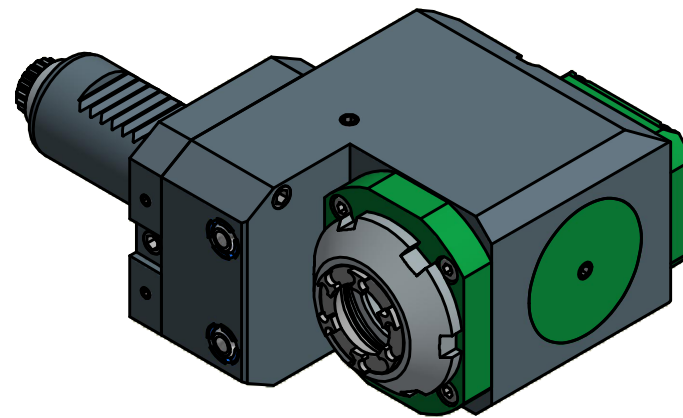
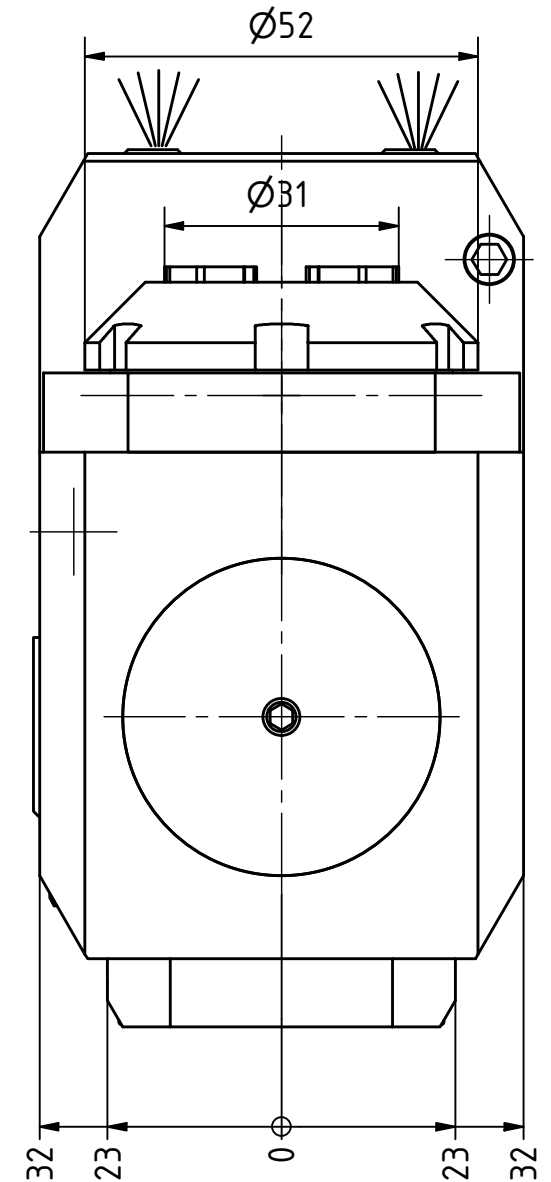
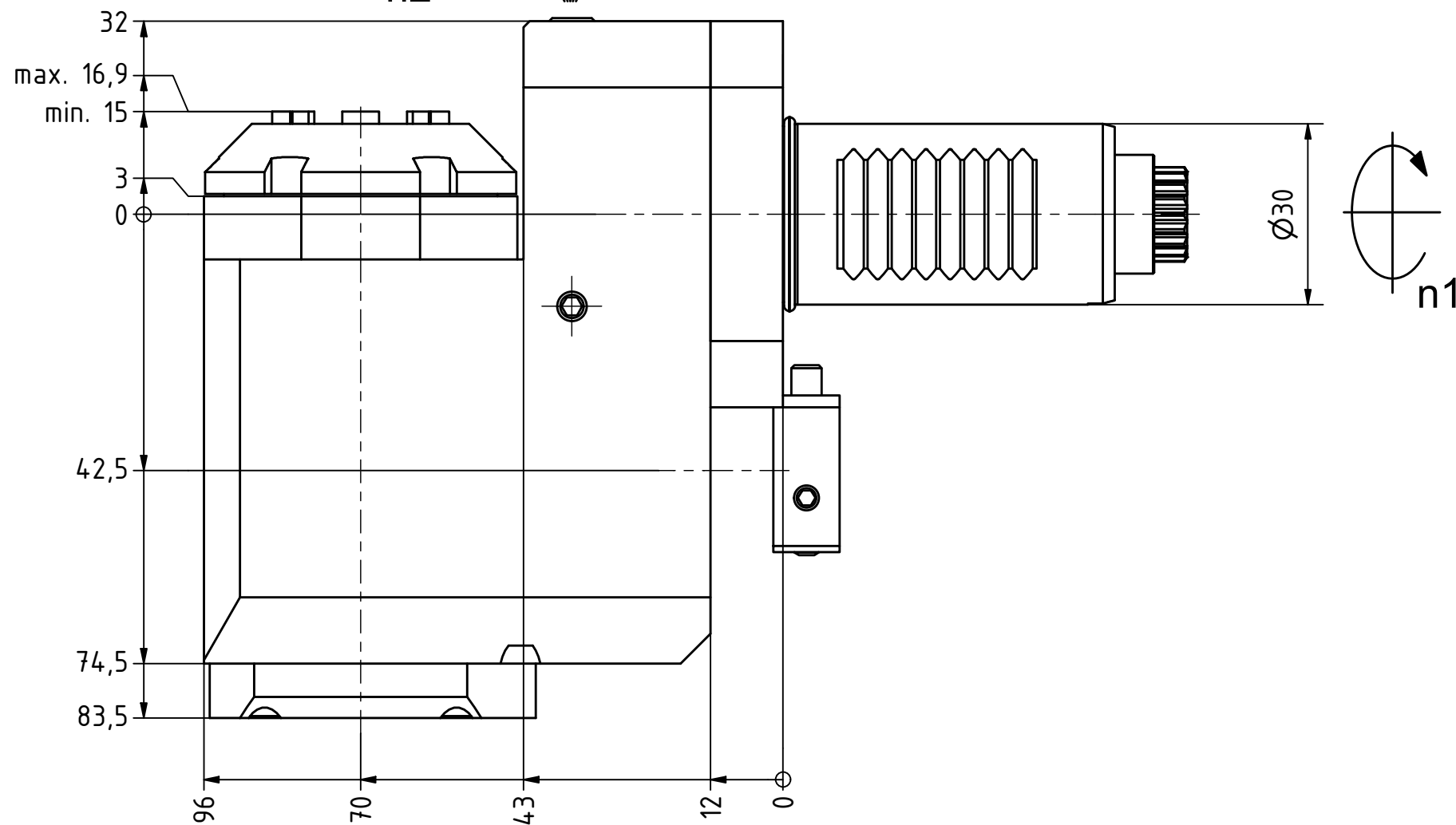
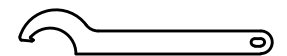

Hakenschlüssel  
 mit Nase  
 Hook wrench with  
 nose end  
 DIN1810 A 52x55

Copyright **EWS Tool Technologies**  
 Weitergabe und Vervielfältigung dieser Unterlage,  
 Verwertung und Mitteilung ihres Inhalts nicht  
 gestattet, soweit nicht ausdrücklich zugestanden.  
 Zuwiderhandlungen verpflichten zu Schadenersatz.

Bemerkung - Note

Technische Daten - technical data

Weight = 3.703 [kg]  
 Torque max. (M1/M2) = 25 / 25 [Nm]  
 Speed max. (n1/n2) = 8000 / 8000 [1/min]  
 Gear ratio (i)=n1:n2 = 1:1

Benennung - Title

Radial Bohr und Fräskopf, zurückges  
 Radial drill. and mill. head offset

**EWS**  
 Tool Technologies

Nr. - No.

80.3025CTXLIM

EWS Weigle GmbH & Co. KG  
 Maybachstr. 1  
 D-73066 UHINGEN  
 www.ews-tools.de

Technische Änderungen vorbehalten!  
 Subject to technical modifications!

IDENT: D-EWS-207867

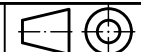

REV: -/-

MNR.

194875

QR