

Spannzange / collet ER32 DIN6499
 Spannbereich / clamping range: 2,0 - 20,0

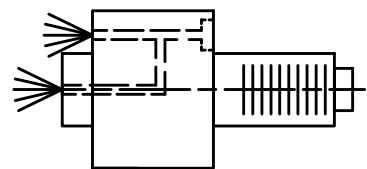

Innen- und Aussenkuehlung / Inside and outside coolant supply
 Kuehlmittelfiltrierung 50μ / coolant filtration 50μ

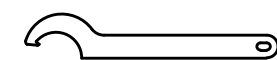
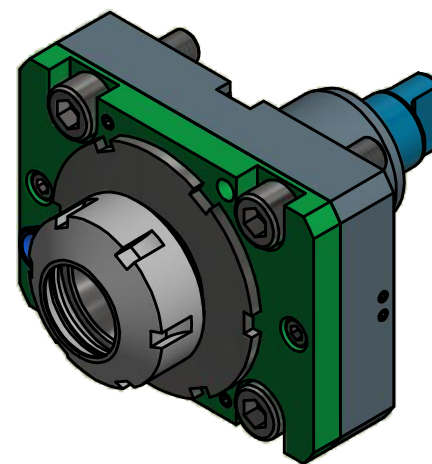

Hakenschlüssel
 mit Nase
 Hook wrench with
 nose end
 DIN1810 A 68x75

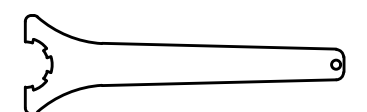

Spannzangenschlüssel
 Clamping wrench
 232

Copyright **EWS Tool Technologies**
 Weitergabe und Vervielfaeltigung dieser Unterlage,
 Verwertung und Mitteilung ihres Inhalts nicht
 gestattet, soweit nicht ausdrecklich zugestanden.
 Zuwiderhandlungen verpflichten zu Schadenersatz.

Bemerkung - Note
 Für Trockenlauf geeignet!
 Use without coolant fluid allowed!

Technische Daten - technical data
 Weight = 2.581 [kg]
 Torque max. (M1/M2) = 32 / 32 [Nm]
 Speed max. (n1/n2) = 12000 / 12000 [1/min]
 Gear ratio (i)=n1:n2 = 1:1
 Pressure (pmax) = 70 [bar]

Benennung - Title
 Axial Bohr und Fräskopf
 Axial drilling and milling head

EWS
 Tool Technologies
 EWS Weigle GmbH & Co. KG
 Maybachstr. 1
 D-73066 UHINGEN
 www.ews-tools.de

Technische Aenderungen vorbehalten!
 Subject to technical modifications!

IDENT: DEWS078113

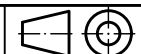

REV: -/C

Nr. - No.

40.4032NZIKCHSD12

MNR.

197815

QR