

Spannzange / collet ER25 DIN6499  
 Spannbereich / clamping range: 1,0 - 16,0

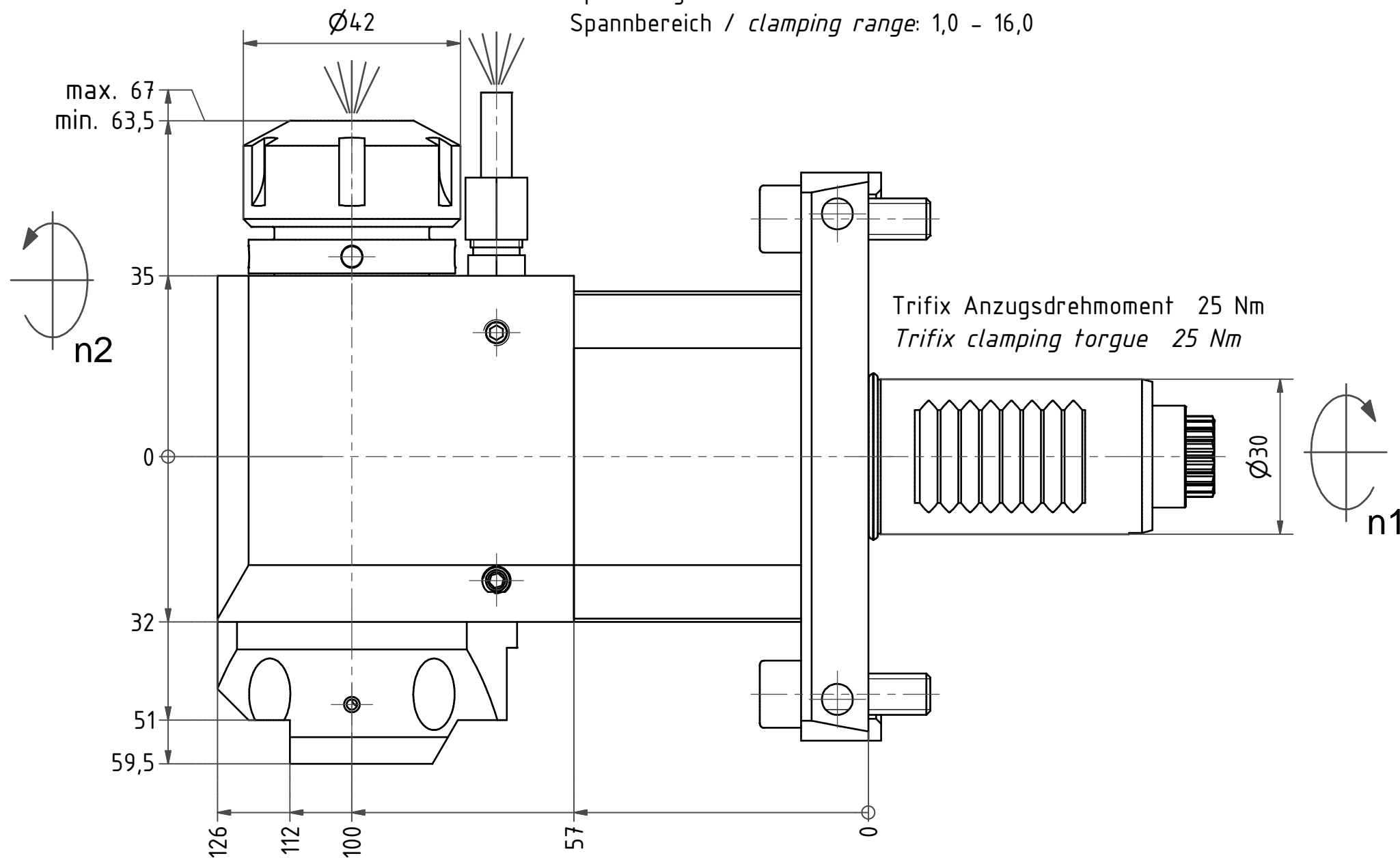

Trifix Anzugsdrehmoment 25 Nm  
 Trifix clamping torque 25 Nm

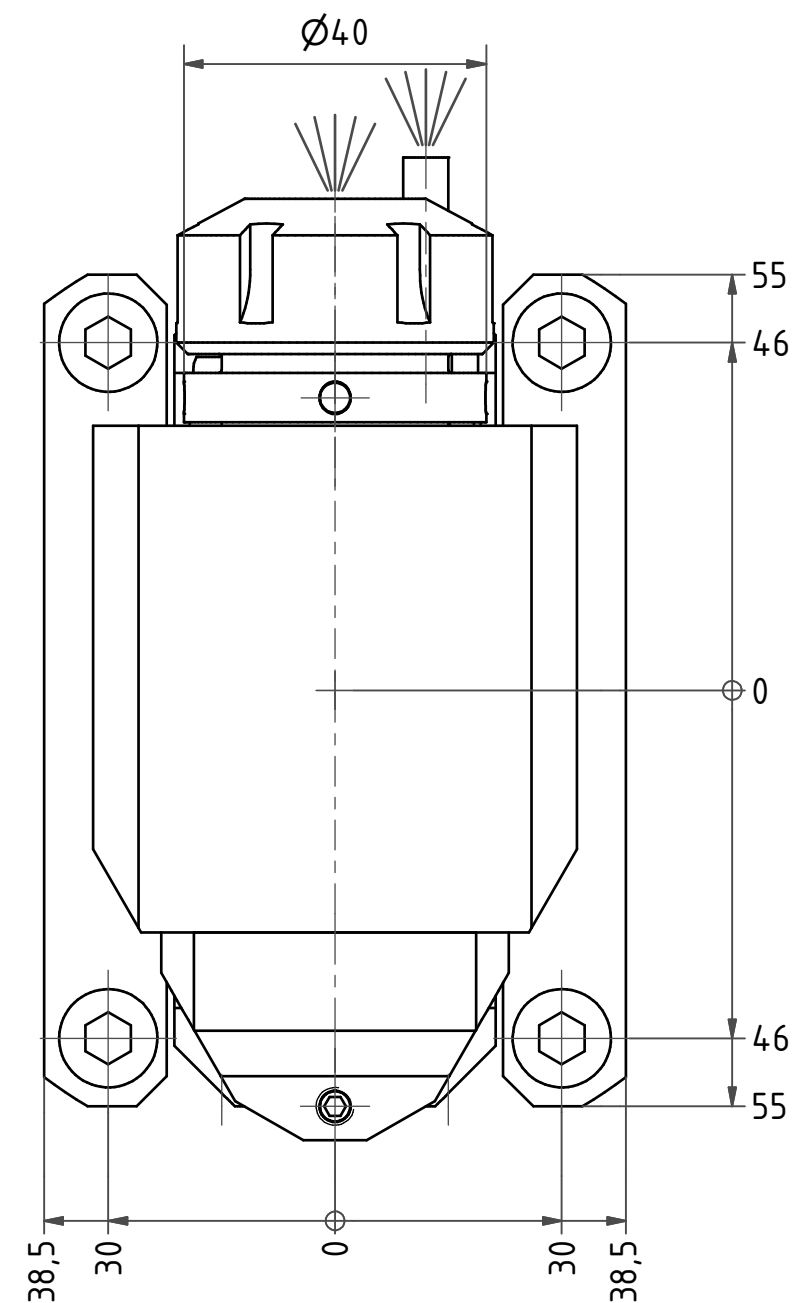

  
 Hakenschlüssel  
 mit Zapfen  
 Hook wrench  
 with fixed pin  
 DIN1810 B 40x42

  
 Spannzangenschlüssel  
 Clamping wrench  
 225

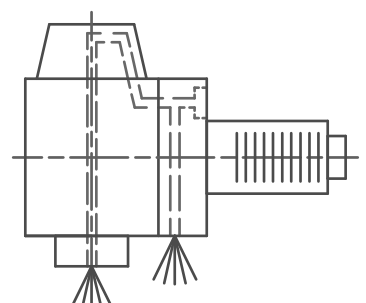
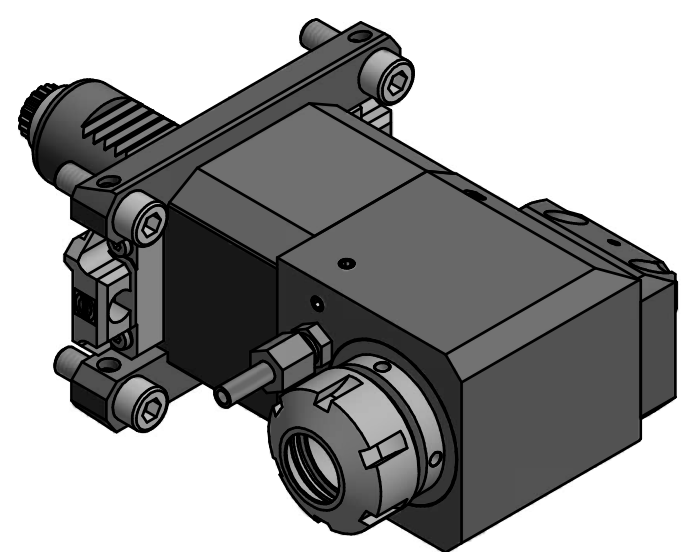

Innen- und Aussenkuehlung / Inside and outside coolant supply  
 Kein Trockenlauf / No dry run  
 Kuehlmittelfiltrierung <math>< 50\mu</math> / coolant filtration <math>< 50\mu</math>

Copyright **EWS Tool Technologies**  
 Weitergabe und Vervielfaeltigung dieser Unterlage,  
 Verwertung und Mitteilung ihres Inhalts nicht  
 gestattet, soweit nicht ausdrecklich zugestanden.  
 Zuwiderhandlungen verpflichten zu Schadenersatz.

Bemerkung - Note  
 Nicht ohne Kuehlmittel betreiben!  
 Not for use without coolant-fluid!

Technische Daten - technical data  
 Weight = 4.565 [kg]  
 Torque max. (M1/M2) = 25 / 25 [Nm]  
 Speed max. (n1/n2) = 8000 / 8000 [1/min]  
 Gear ratio (i)=n1:n2 = 1:1  
 Pressure (pmax) = 70 [bar]

Benennung - Title  
**Radial Bohr und Fräskopf**  
**Radial drilling and milling head**

**EWS** Tool Technologies  
 EWS Weigele GmbH & Co. KG  
 Maybachstr. 1  
 D-73066 Uhingen  
 www.ews-tools.de

Technische Aenderungen vorbehalten!  
 Subject to technical modifications!  
 IDENT: D-EWS-211298  
 Nr. - No. 60.3025LCTXLIKTF-PL

REV: -/-  
 MNR. 195983

