

Spannzange / collet ER25 DIN6499
Spannbereich / clamping range: 1,0 - 16,0

Gewindebohrzange / tapping collet
ET-1-25 M3-M12

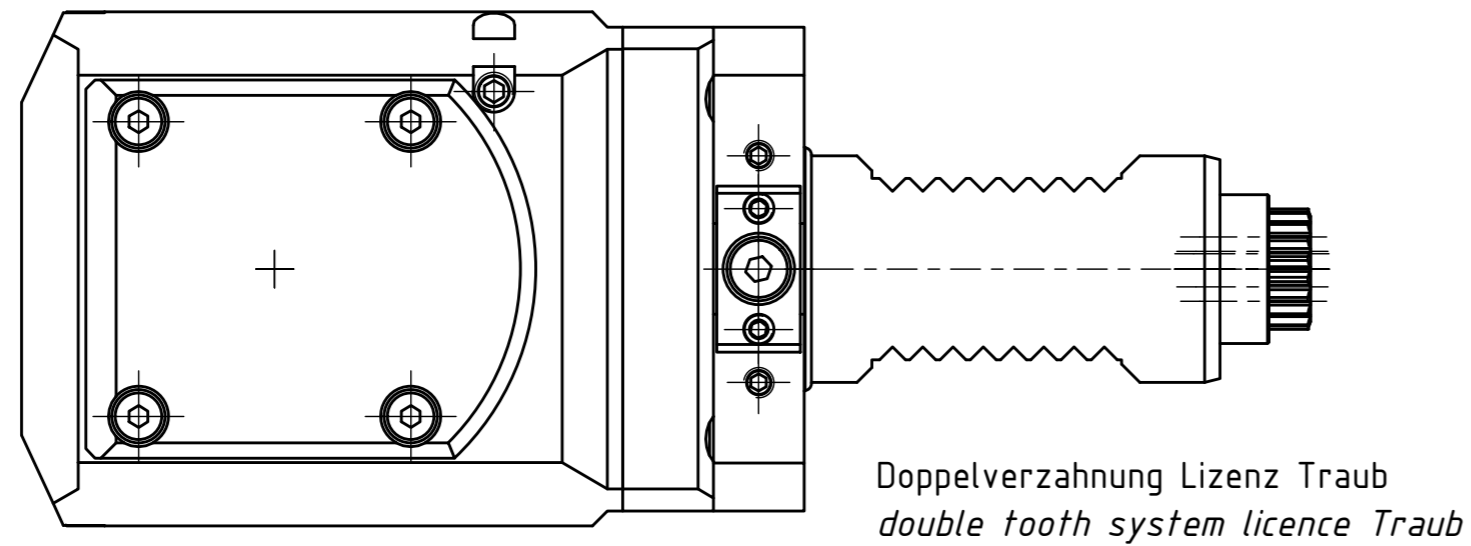

Doppelverzahnung Lizenz Traub
double tooth system licence Traub

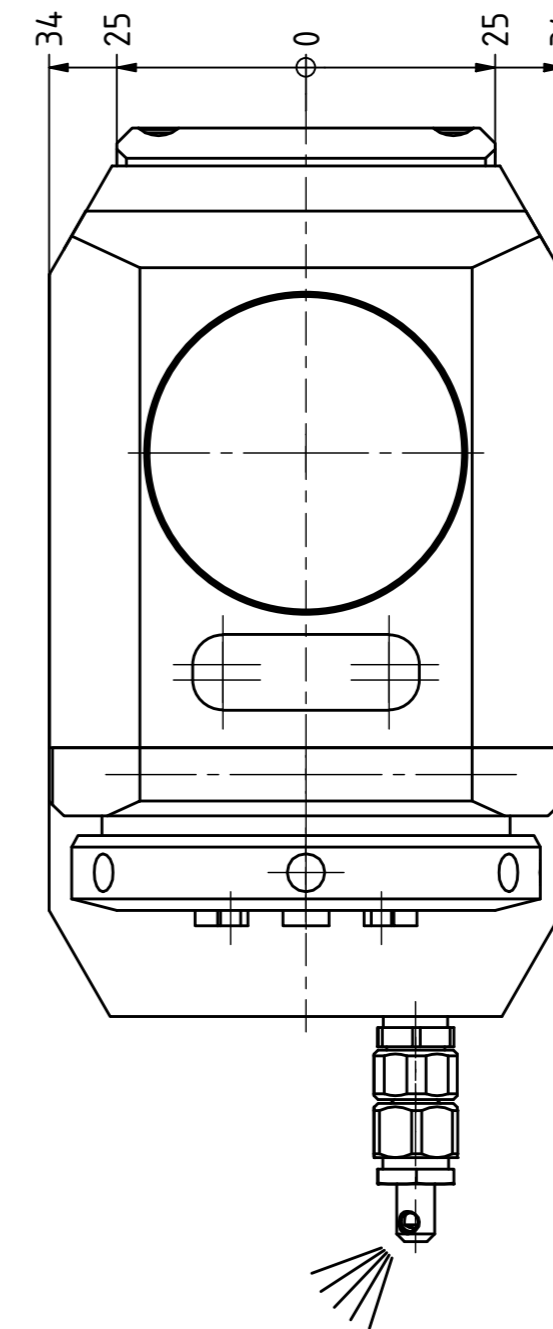
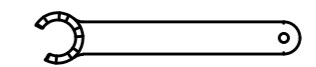
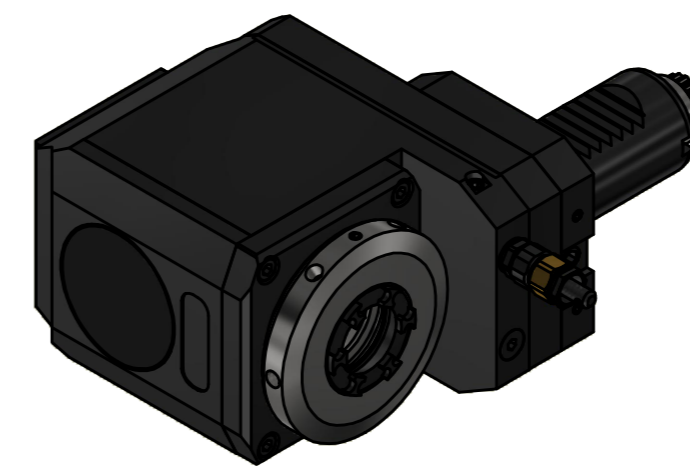

Spannzangenschlüssel für
innenliegende Mutter
Clamping wrench for
internal collet
225AX

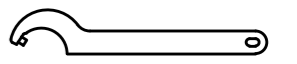

Hakenschlüssel
mit Zapfen
Hook wrench
with fixed pin
DIN1810 B 58x62
225AX

Copyright **EWS Tool Technologies**
Weitergabe und Vervielfältigung dieser Unterlage,
Verwertung und Mitteilung ihres Inhalts nicht
gestattet, soweit nicht ausdrücklich zugestanden.
Zuwendungen verpflichten zu Schadenersatz.

Bemerkung - Note	Technische Daten - technical data Weight = 4,277 [kg] Torque max. (M1/M2) = 32 / 32 [Nm] Speed max. (n1/n2) = 8000 / 8000 [1/min] Gear ratio (i)=n1:n2 = 1:1	Benennung - Title Radial Bohr und Fräskopf, zurückges Radial drill. and mill. head offset	 EWS Weigle GmbH & Co. KG Maybachstr. 1 D-73066 Uhlingen www.ews-tool.de Nr. - No. 80.3025CTXRLIM#01	Technische Änderungen vorbehalten! Subject to technical modifications! IDENT: DEWS229809 MNR. REV: -/E 193124	
------------------	--	---	---	---	--