

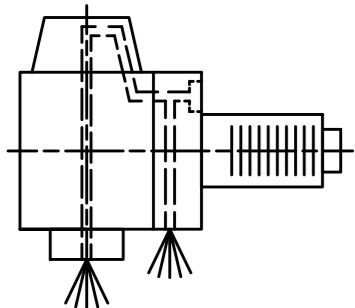

Ceramic Seal

Tech Details

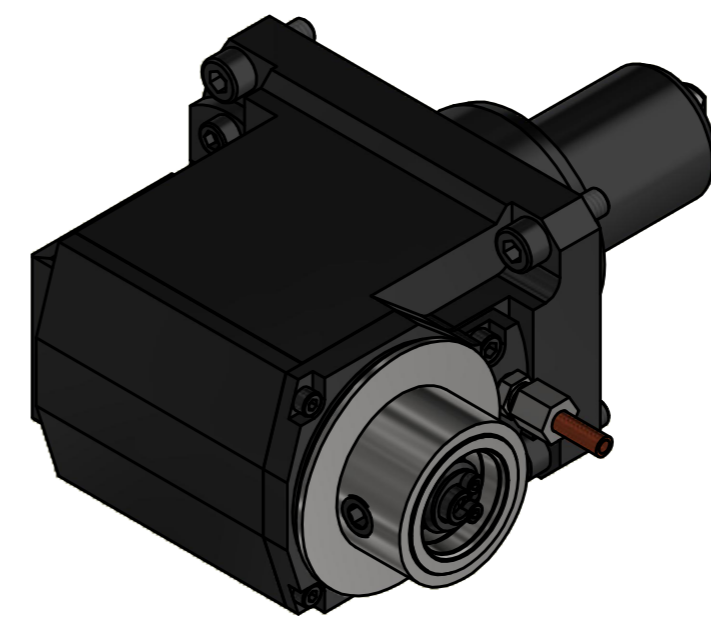
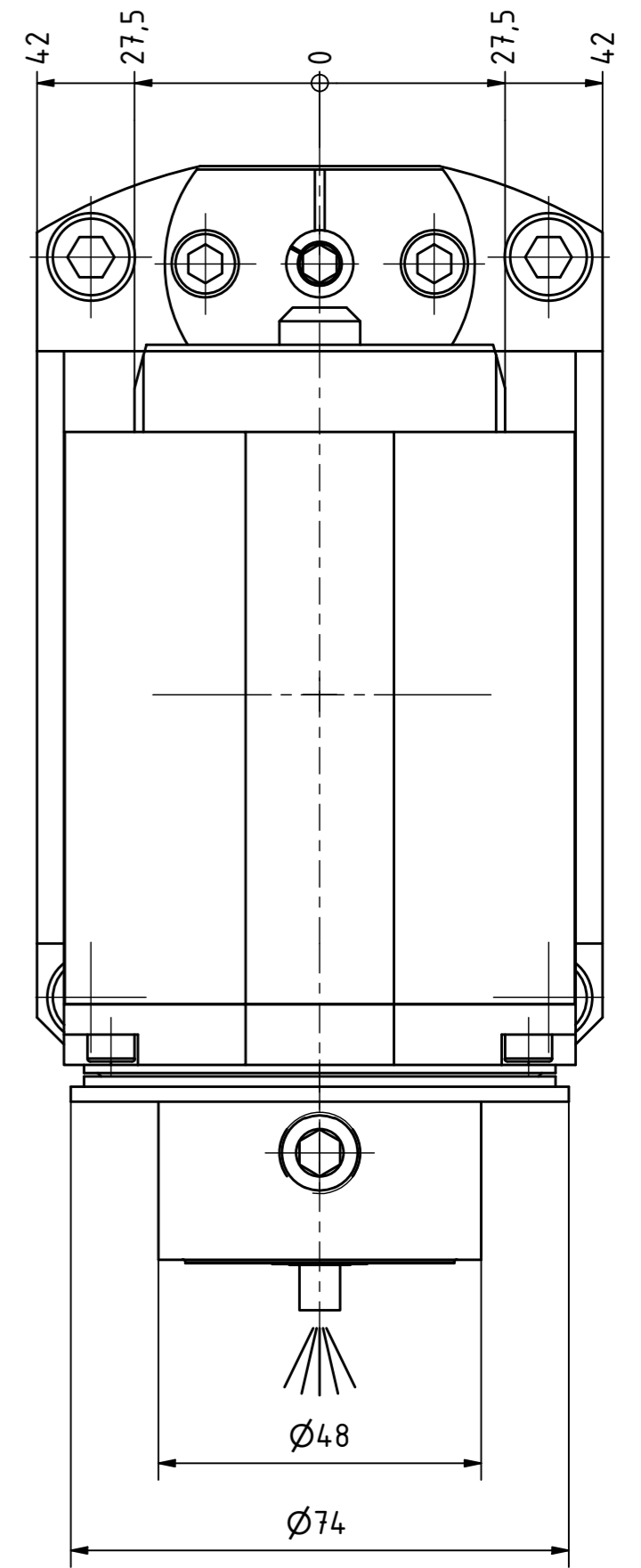
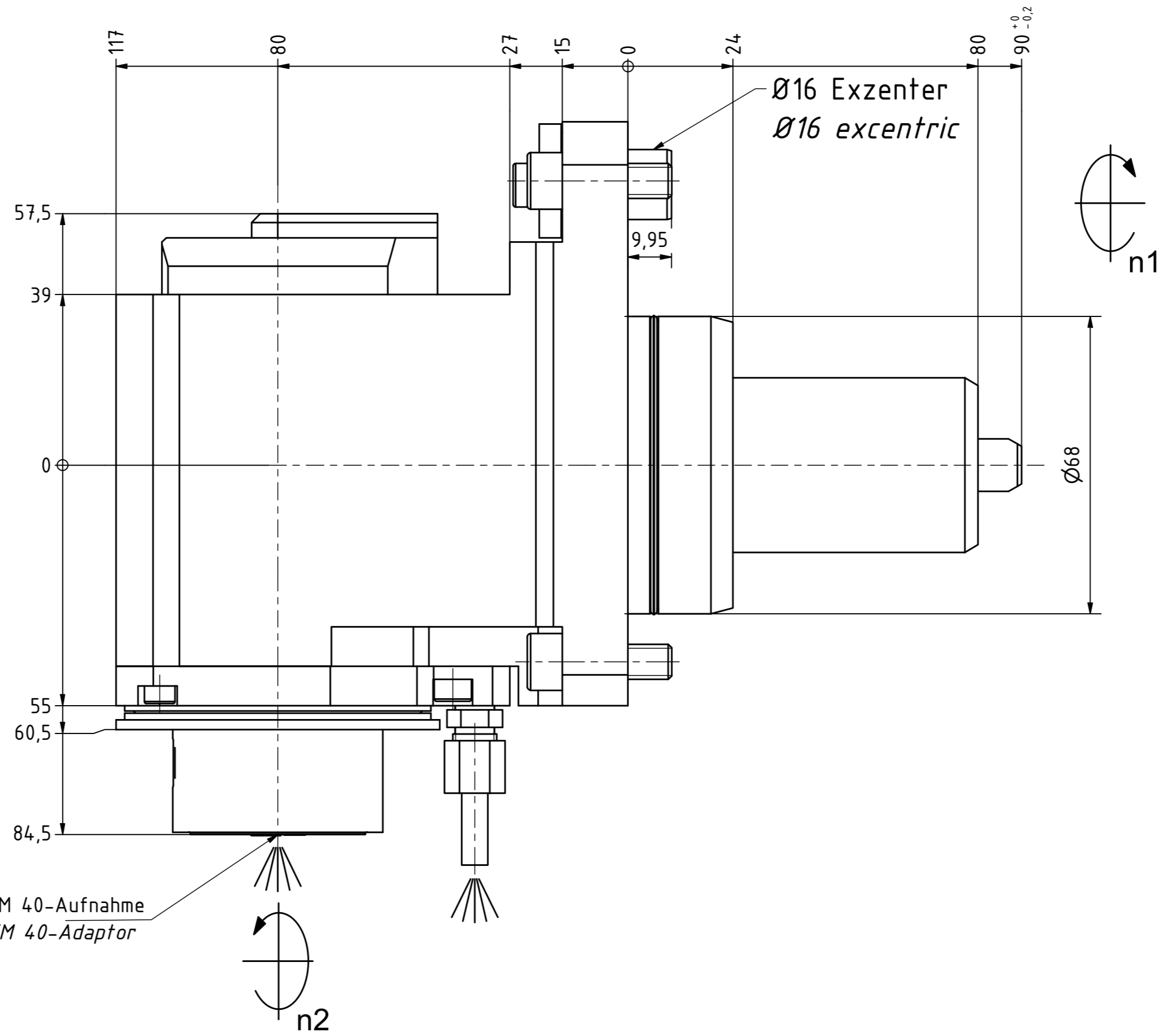
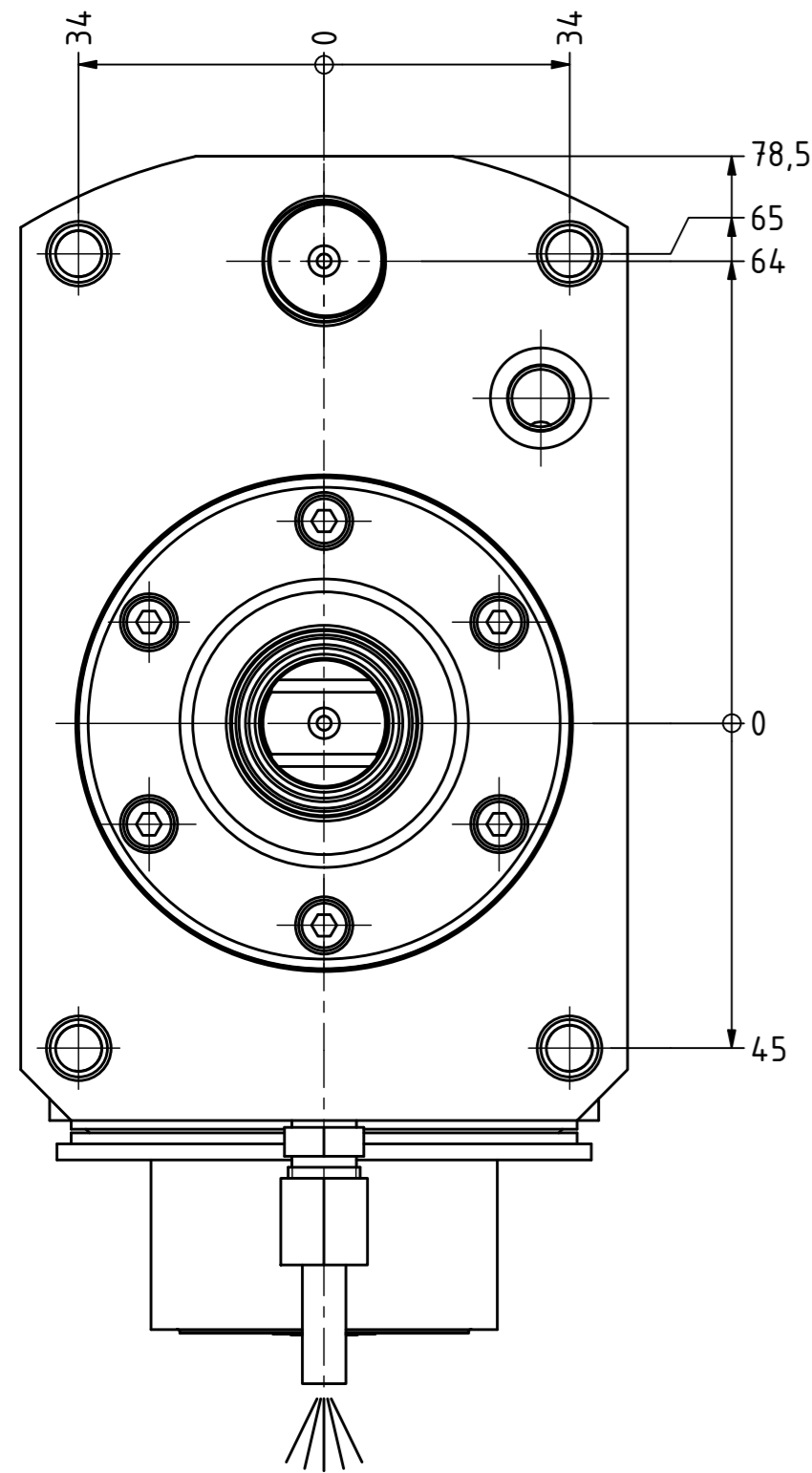

Innen- und Aussenkuehlung / Inside and outside coolant supply
 Kuehlmittelfiltrierung-50µ / coolant filtration-50µ

KM 40-Aufnahme
 KM 40-Adaptor

Copyright **EWS Tool Technologies**
 Weitergabe und Vervielfaeltigung dieser Unterlage,
 Verwertung und Mitteilung ihres Inhalts nicht
 gestattet, soweit nicht ausdrecklich zugestanden.
 Zuwiderhandlungen verpflichten zu Schadenersatz.

Bemerkung - Note
 Für Trockenlauf geeignet!
 Use without coolant fluid allowed!

Technische Daten - technical data
 Weight = 7.602 [kg]
 Torque max. (M1/M2) = 50 / 50 [Nm]
 Speed max. (n1/n2) = 6000 / 6000 [1/min]
 Gear ratio (i)=n1:n2 = 1:1
 Pressure (pmax) = 70 [bar]

Benennung - Title
Radial Bohr und Fräskopf
Radial drilling and milling head

EWS Tool Technologies
 EWS Weigle GmbH & Co. KG
 Maybachstr. 1
 D-73066 Uhlingen
 www.ews-tool.de

Technische Aenderungen vorbehalten!
 Subject to technical modifications!
 IDENT: DEWS238838

REV: -/D
 MNR.

Nr. - No.
60.68KM40QSMBMTIKD

195522

