

Trifix Anzugsdrehmoment 50 Nm
 Trifix clamping torque 50 Nm

Doppelverzahnung Lizenz Traub
 double tooth system licence Traub

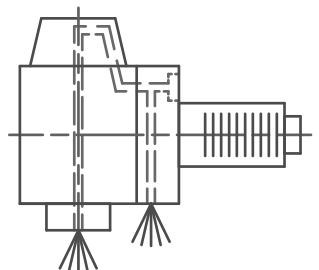
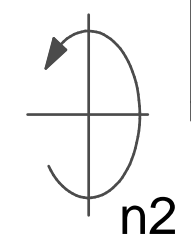
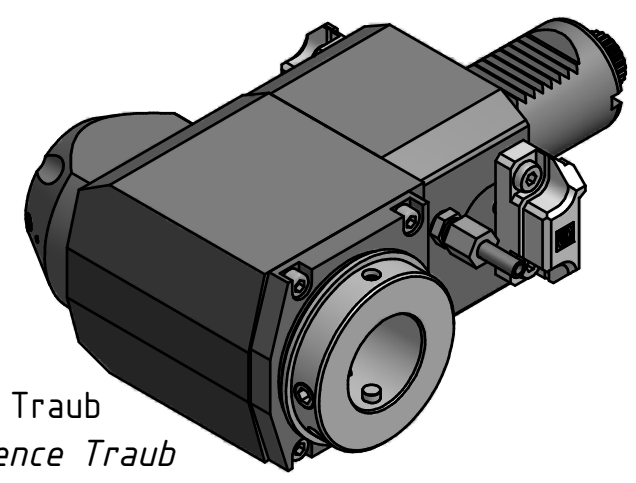

Innen- und Aussenkuehlung / Inside and outside coolant supply
 Kein Trockenlauf / No dry run
 Kuehlmittelfiltrierung<50µ / coolant filtration<50µ

Copyright **EWS Tool Technologies**
 Weitergabe und Vervielfaeltigung dieser Unterlage,
 Verwertung und Mitteilung ihres Inhalts nicht
 gestattet, soweit nicht ausdrecklich zugestanden.
 Zuwiderhandlungen verpflichten zu Schadenersatz.

<p>Bemerkung - Note</p> <p>Nicht ohne Kuehlmittel betreiben! <i>Not for use without coolant-fluid!</i></p>	<p>Technische Daten - technical data</p> <p>Weight = 7.181 [kg] Torque max. (M1/M2) = 50 / 50 [Nm] Speed max. (n1/n2) = 10.000 / 10.000 [1/min] Gear ratio (i)=n1:n2 = 1:1 Pressure (pmax) = 70 [bar]</p>	<p>Benennung - Title</p> <p>Radial Bohr und Fräskopf <i>Radial drilling and milling head</i></p>	<p>EWS Tool Technologies</p> <p><small>EWS Weigele GmbH & Co. KG Maybachstr. 1 D-73066 Uthingen www.ews-tools.de</small></p> <p>Nr. - No. 60.40V4CTXRLIKTRHSD</p>	<p>Technische Aenderungen vorbehalten! <i>Subject to technical modifications!</i></p> <p>IDENT: D-EWS-203860</p> <p>MNR. 192973</p>	
---	---	--	--	--	---