

Spannzange / collet ER40 DIN6499
Spannbereich / clamping range: 3,0 - 26,0

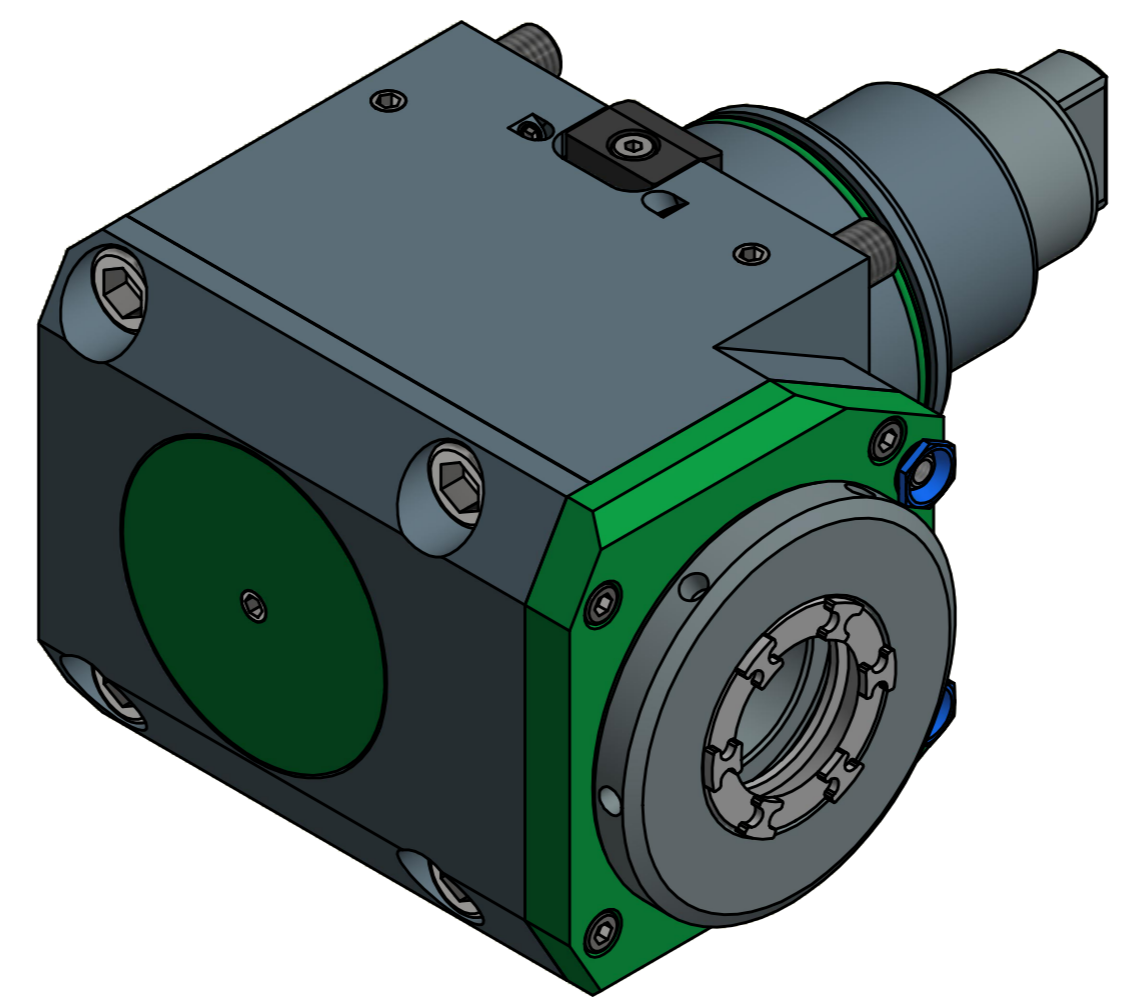

Gewindebohrzange / tapping collet
ET-1-40 M6-M16

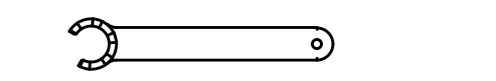

Hakenschlüssel
mit Zapfen
Hook wrench
with fixed pin
DIN1810 B 80x90

Spannzangenschlüssel für
innenliegende Mutter
Clamping wrench for
internal collet
240AX

Copyright **EWS Tool Technologies**
Weitergabe und Vervielfältigung dieser Unterlage,
Verwertung und Mitteilung ihres Inhalts nicht
gestattet, soweit nicht ausdrücklich zugestanden.
Zuwerhandlungen verpflichten zu Schadenersatz.

Bemerkung - Note	Technische Daten - technical data Weight = 12.235 [kg] Torque max. (M1/M2) = 100 / 100 [Nm] Speed max. (n1/n2) = 6000 / 6000 [1/min] Gear ratio (i)=n1:n2 = 1:1	Benennung - Title Radial Bohr und Fräskopf Radial drilling and milling head	 EWS Weigle GmbH & Co. KG Maybachstr. 1 D-73066 Uhingen www.ews-tools.de Nr. - No. 60.7540VL8GLIM	Technische Änderungen vorbehalten! Subject to technical modifications! IDENT: DEWS089405 MNR. REV: -/A 191825	
------------------	---	---	--	---	---