

Spannzange / collet ER40 DIN6499
 Spannbereich / clamping range: 3,0 - 26,0

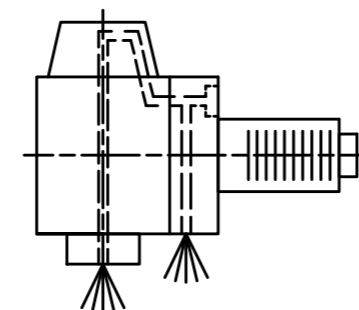
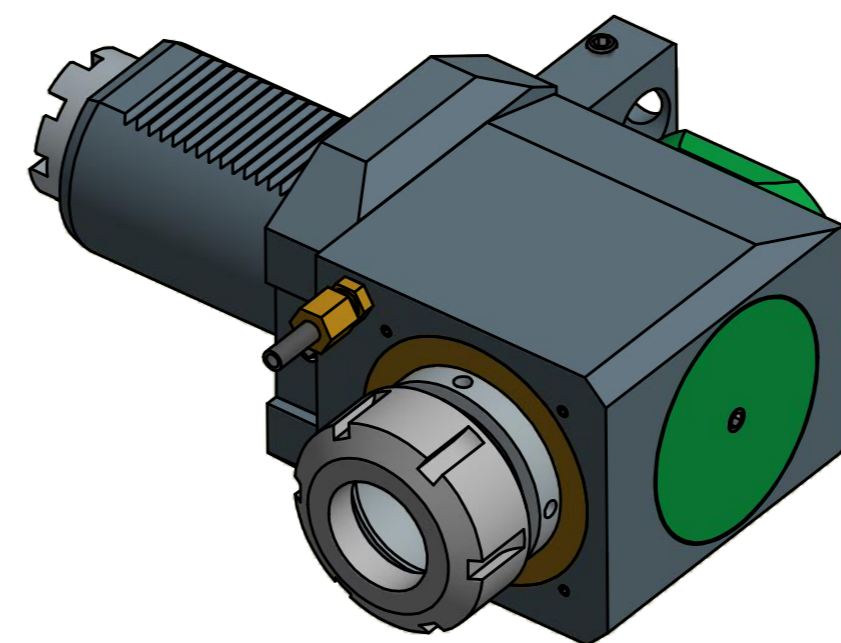
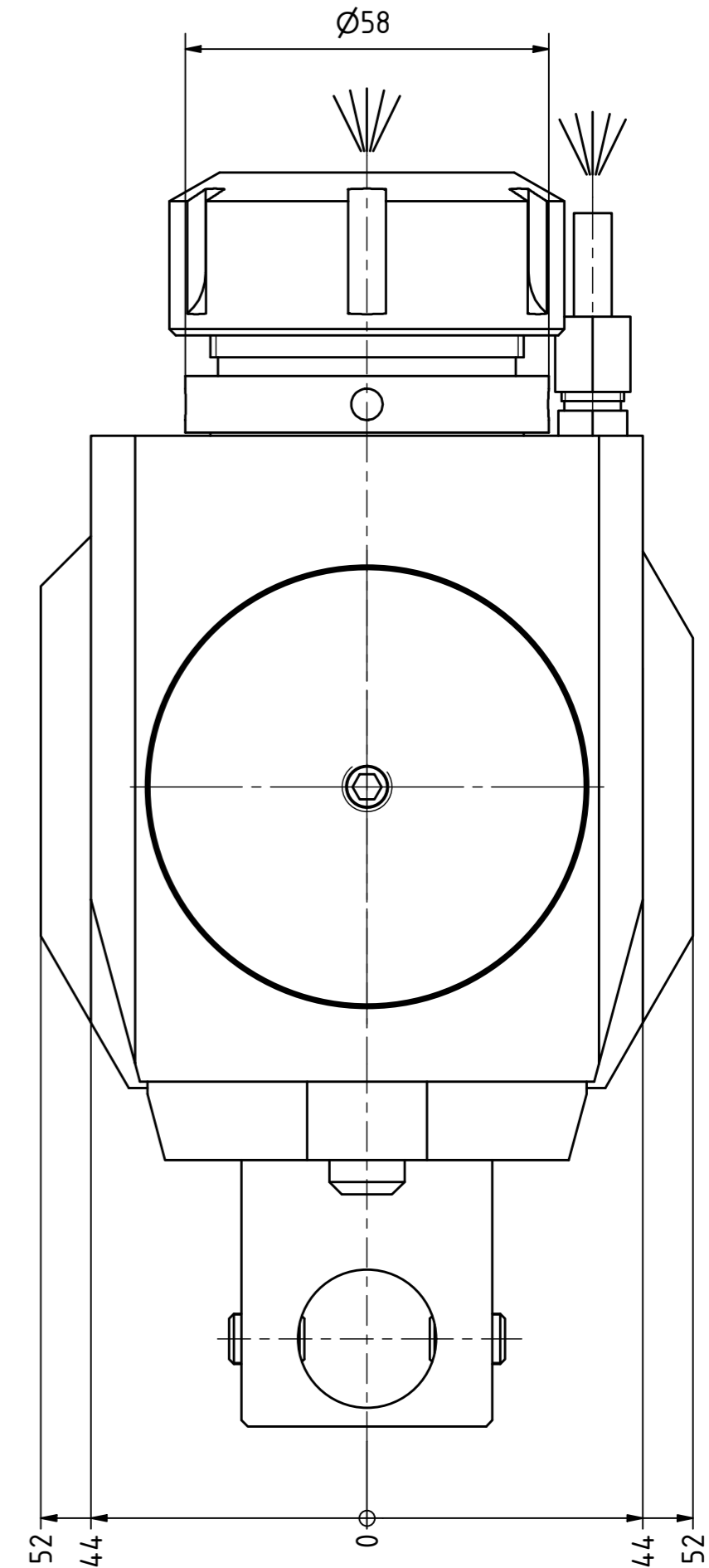

Innen- und Aussenkuehlung / Inside and outside coolant supply
 Kuehlmittelfiltrierung50μ / coolant filtration50μ

Hakenschlüssel mit Zapfen
 Hook wrench with fixed pin
 DIN1810 B 58x62

Spannzangenschlüssel
 Clamping wrench
 240

Copyright **EWS Tool Technologies**
 Weitergabe und Vervielfaeltigung dieser Unterlage, Verwertung und Mitteilung ihres Inhalts nicht gestattet, soweit nicht ausdrecklich zugestanden. Zuwiderhandlungen verpflichten zu Schadenersatz.

<p>Bemerkung - Note Für Trockenlauf geeignet! Use without coolant fluid allowed!</p>	<p>Technische Daten - technical data Weight = 9.407 [kg] Torque max. (M1/M2) = 100 / 100 [Nm] Speed max. (n1/n2) = 4000 / 4000 [1/min] Gear ratio (i)=n1:n2 = 1:1 Pressure (pmax) = 70 [bar]</p>	<p>Benennung - Title Radial Bohr und Fräskopf Radial drilling and milling head</p>	<p>EWS Tool Technologies EWS Weigle GmbH & Co. KG Maybachstr. 1 D-73066 Uhlingen www.ews-tool.de</p> <p>Technische Aenderungen vorbehalten! Subject to technical modifications! IDENT: D-EWS-198168</p>	<p>Nr. - No. 60.6040TOEMLIKDGL</p> <p>REV: -/- MNR. 190990</p> <p>QR</p>
--	---	--	--	--