

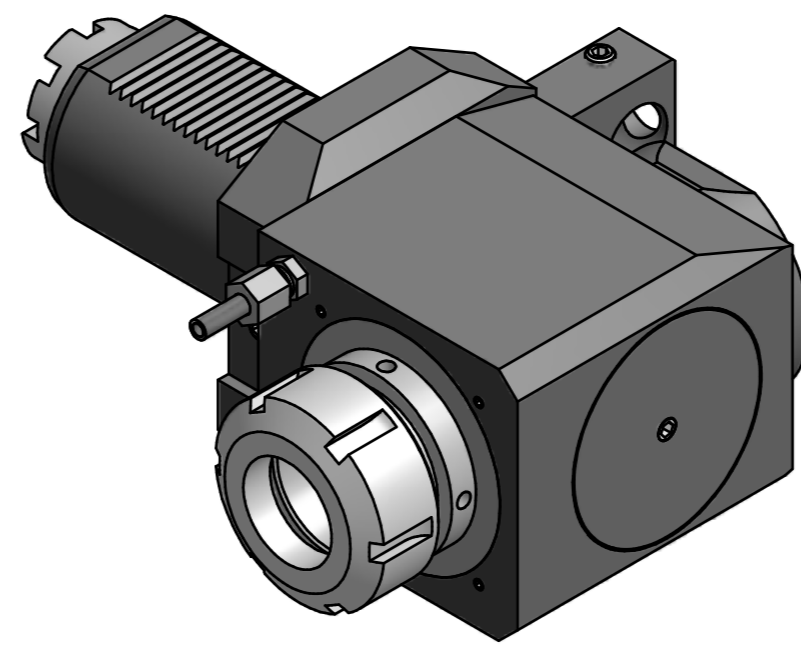

Spannzange / collet ER40 DIN6499  
Spannbereich / clamping range: 3,0 - 26,0

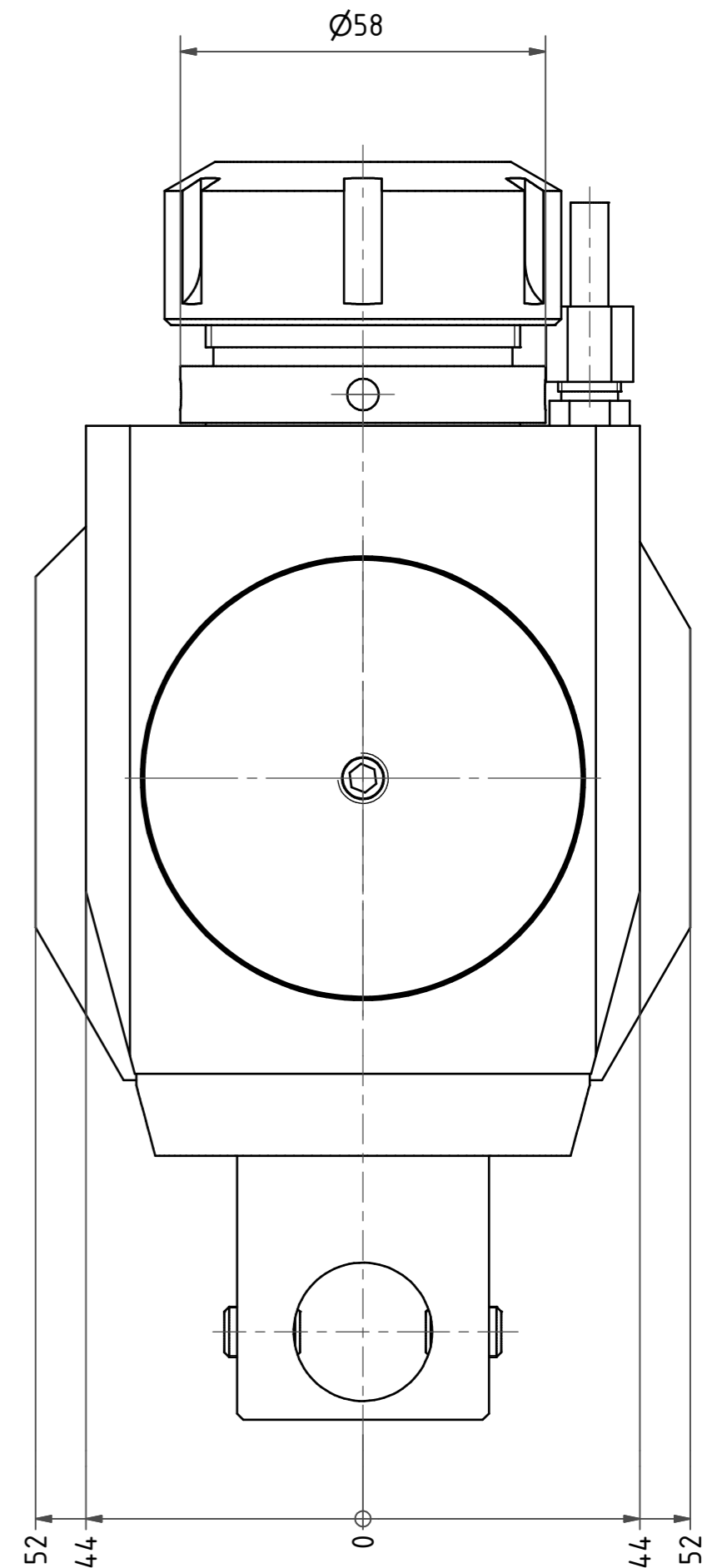

Gewindebohrzange / tapping collet  
ET-1-40 M6-M16

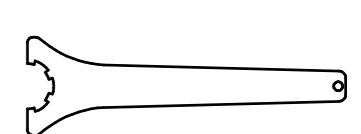

 Hakenschlüssel mit Zapfen  
 Hook wrench with fixed pin  
 DIN1810 B 58x62

 Spannzangenschlüssel  
 Clamping wrench  
 240

Copyright **EWS Tool Technologies**  
Weitergabe und Vervielfältigung dieser Unterlage, Verwertung und Mitteilung ihres Inhalts nicht gestattet, soweit nicht ausdrücklich zugestanden. Zuwiderhandlungen verpflichten zu Schadenersatz.

Bemerkung - Note	Technische Daten - technical data Weight = 9,400 [kg] Torque max. (M1/M2) = 100 / 100 [Nm] Speed max. (n1/n2) = 4,000 / 4,000 [1/min] Gear ratio (i)=n1:n2 = 1:1	Benennung - Title <b>Radial Bohr und Fräskopf</b> <i>Radial drilling and milling head</i>	 <b>EWS</b> Weigle GmbH & Co. KG Maybachstr. 1 D-73066 Ulm/Ingen www.ews-tools.de	Technische Änderungen vorbehalten! Subject to technical modifications! IDENT: D-EWS-198157 REV: -/- MNR. <b>190989</b>	
------------------	--	---	---	---	---