

EWS.Varia

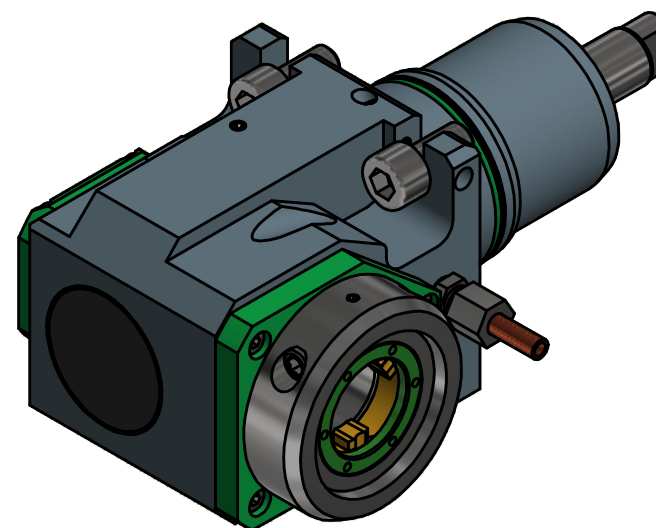

Tech  
Details

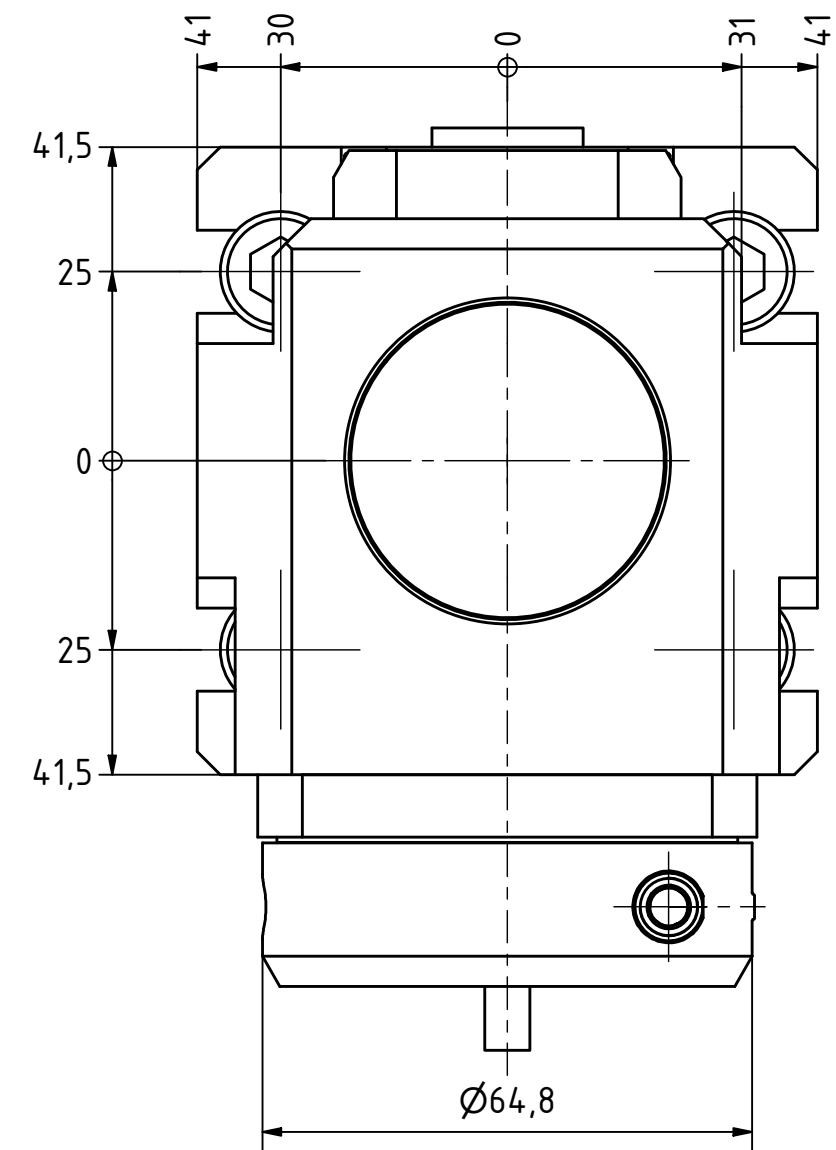
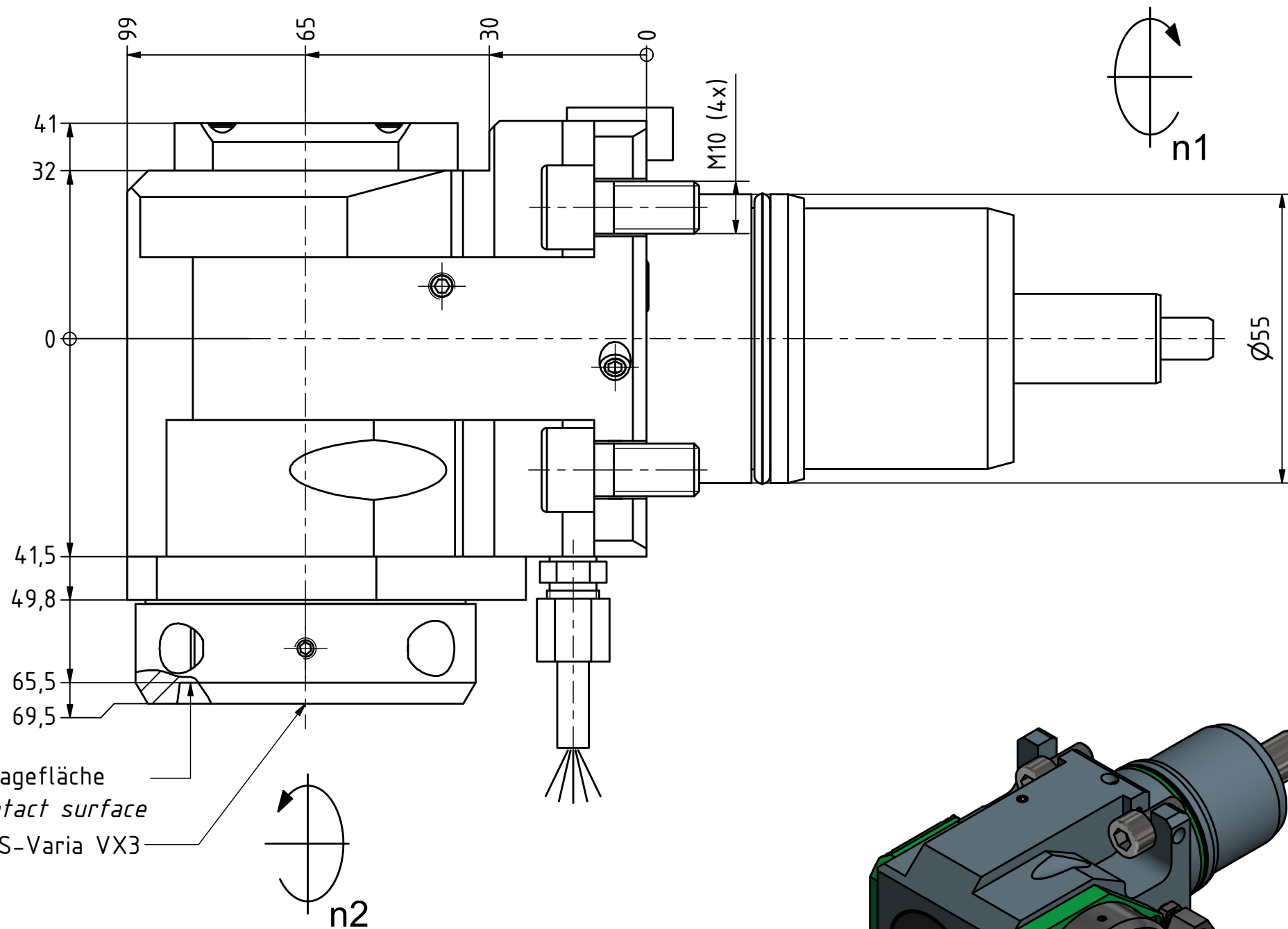

Copyright **EWS Tool Technologies**  
 Weitergabe und Vervielfältigung dieser Unterlage,  
 Verwertung und Mitteilung ihres Inhalts nicht  
 gestattet, soweit nicht ausdrücklich zugestanden.  
 Zuwiderhandlungen verpflichten zu Schadenersatz.

Bemerkung - Note

Technische Daten - technical data

Weight = 4.784 [kg]  
 Torque max. (M1/M2) = 25 / 25 [Nm]  
 Speed max. (n1/n2) = 6000 / 6000 [1/min]  
 Gear ratio (i)=n1:n2 = 1:1

Benennung - Title

**Radial Bohr und Fräskopf**  
**Radial drilling and milling head**



EWS Weigele GmbH & Co. KG  
 Maybachstr. 1  
 D-73066 UHINGEN  
 www.ews-tools.de

Technische Änderungen vorbehalten!  
 Subject to technical modifications!

IDENT: DEWS124-890



REV: -/E

Nr. - No.

60.55VX3WT150X65

MNR.

192598

QR