

W-Verzahnung Lizenz Index-Werke
W-tooth system licence Index-Corporation

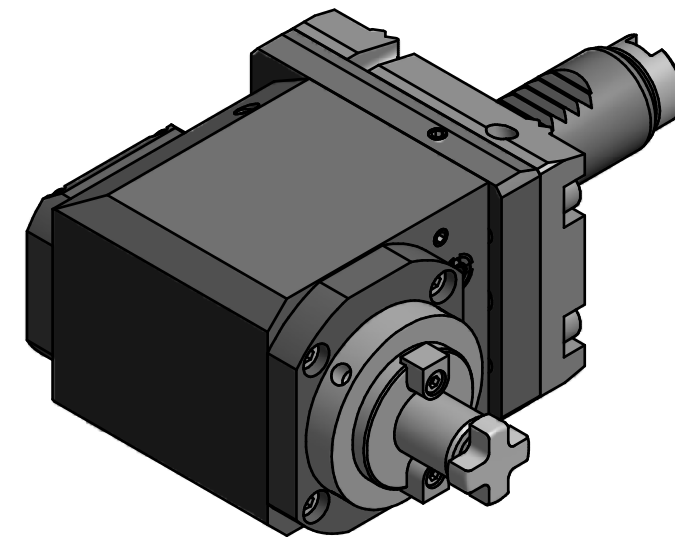

 Hakenschlüssel
 mit Zapfen
*Hook wrench
 with fixed pin*
 DIN1810 B 45x50

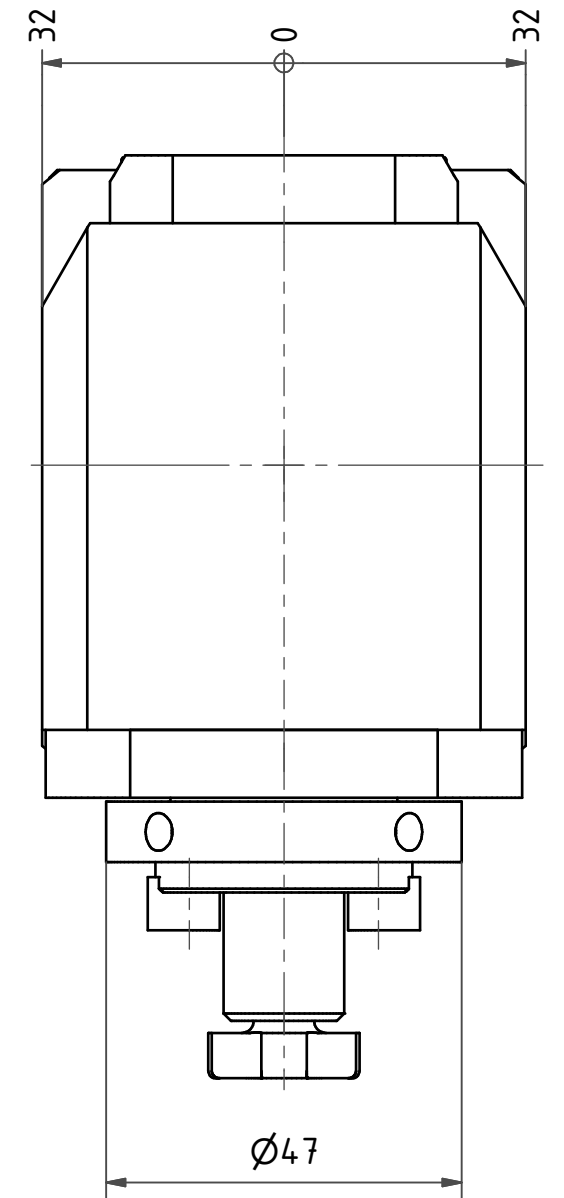
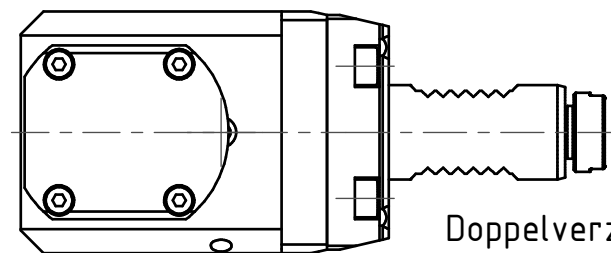

Doppelverzahnung Lizenz Traub
double tooth system licence Traub

Copyright **EWS Tool Technologies**
 Weitergabe und Vervielfaeltigung dieser Unterlage,
 Verwertung und Mitteilung ihres Inhalts nicht
 gestattet, soweit nicht ausdrecklich zugestanden.
 Zuwiderhandlungen verpflichten zu Schadenersatz.

Bemerkung - Note
 mit Kegelrollenlager
with taper roller bearing(s)

Technische Daten - technical data
 Weight = 3.394 [kg]
 Torque max. (M1/M2) = 25 / 25 [Nm]
 Speed max. (n1/n2) = 6000 / 6000 [1/min]
 Gear ratio (i)=n1:n2 = 1:1

Benennung - Title
Radial Fräskopf
Radial milling head

EWS Tool Technologies
 EWS Weigle GmbH & Co. KG
 Maybachstr. 1
 D-73066 Uhingen
 www.ews-tools.de
 Nr. - No.
62.2516KRG200RLW

Technische Aenderungen vorbehalten!
Subject to technical modifications!
 IDENT: D-EWS-204719
 MNR.
193299

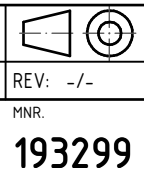

QR