

(1:2)

Doppelverzahnung Lizenz Traub  
double tooth system licence Traub

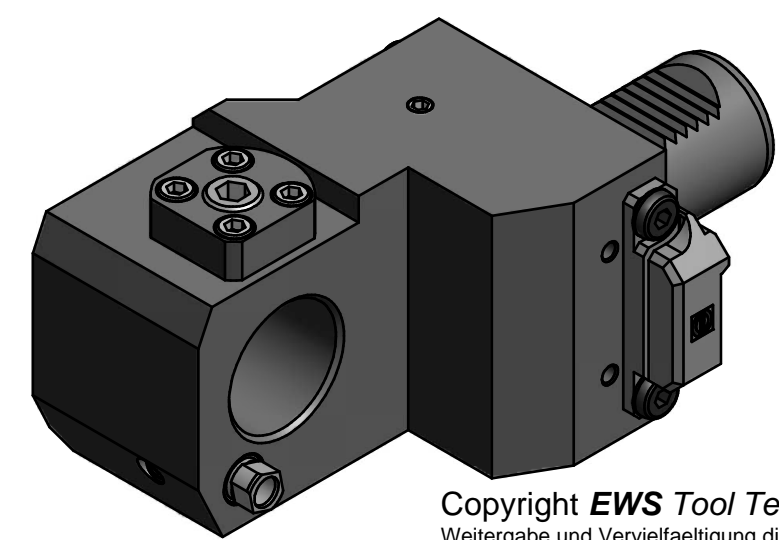
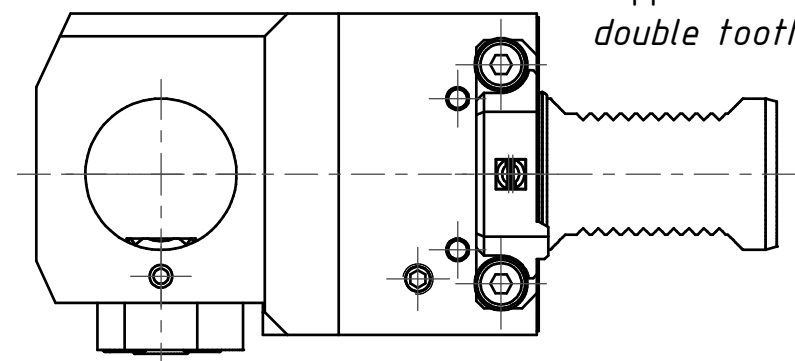

Copyright **EWS Tool Technologies**  
Weitergabe und Vervielfaeltigung dieser Unterlage,  
Verwertung und Mitteilung ihres Inhalts nicht  
gestattet, soweit nicht ausdruuecklich zugestanden.  
Zuwaiderhandlungen verpflichten zu Schadenersatz.

Bemerkung - Note	Technische Daten - technical data <b>Weight</b> = 5.986 [kg]	Benennung - Title <b>Ausgleichhalter</b> <i>Tool holder adapter</i>	EWS Weigele GmbH & Co. KG Maybachstr. 1 D-73066 Utingen www.ews-tools.de	Technische Aenderungen vorbehalten! <i>Subject to technical modifications!</i> IDENT: D-EWS-197508	REV: -/- MNR. <b>190750</b>	
------------------	---	---	---	--	-----------------------------------	--