

* Bemerkung: für die SPINNER TC77SMCY/TC110SMCY Maschine (mit Gegenspindel) sind 130mm ausreichend!
 Note: for the SPINNER TC77SMCY/TC110SMCY machine (with opposed spindle) are 130mm sufficient!

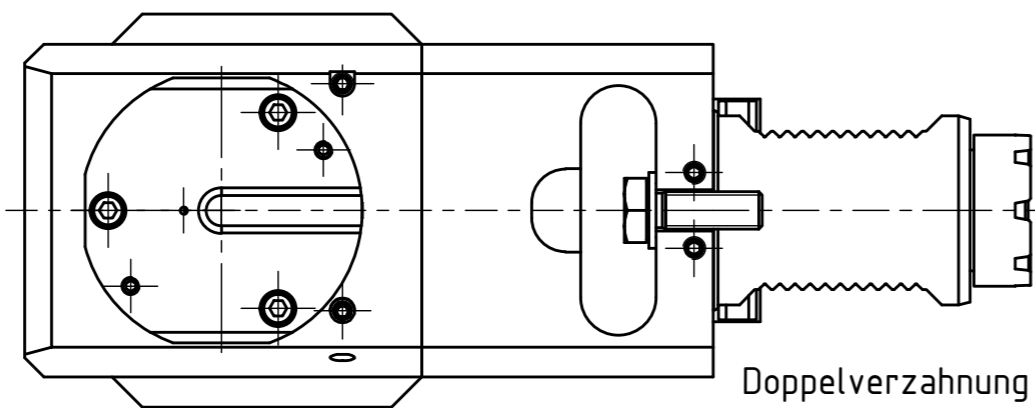

Doppelverzahnung Lizenz Traub
 double tooth system licence Traub

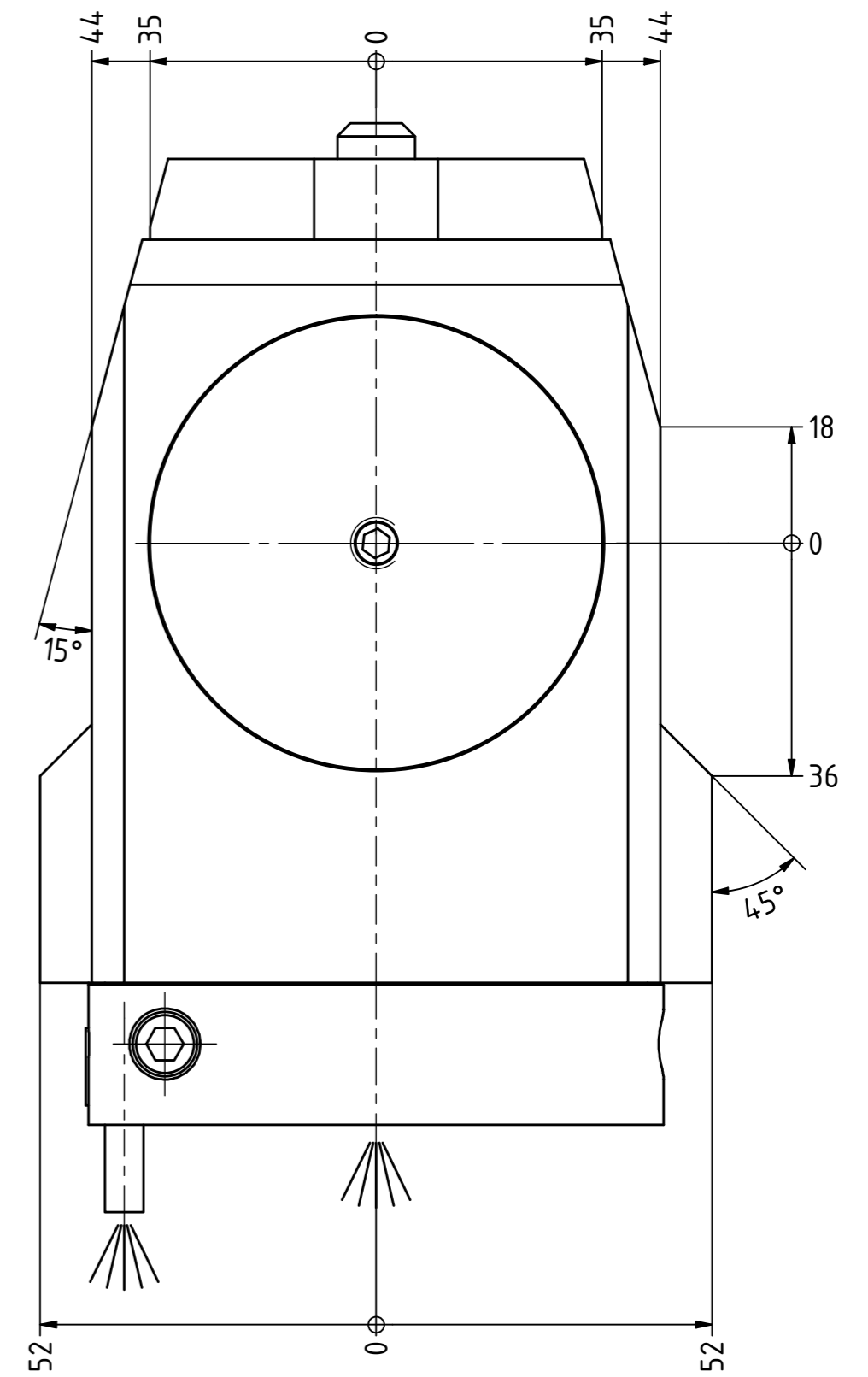
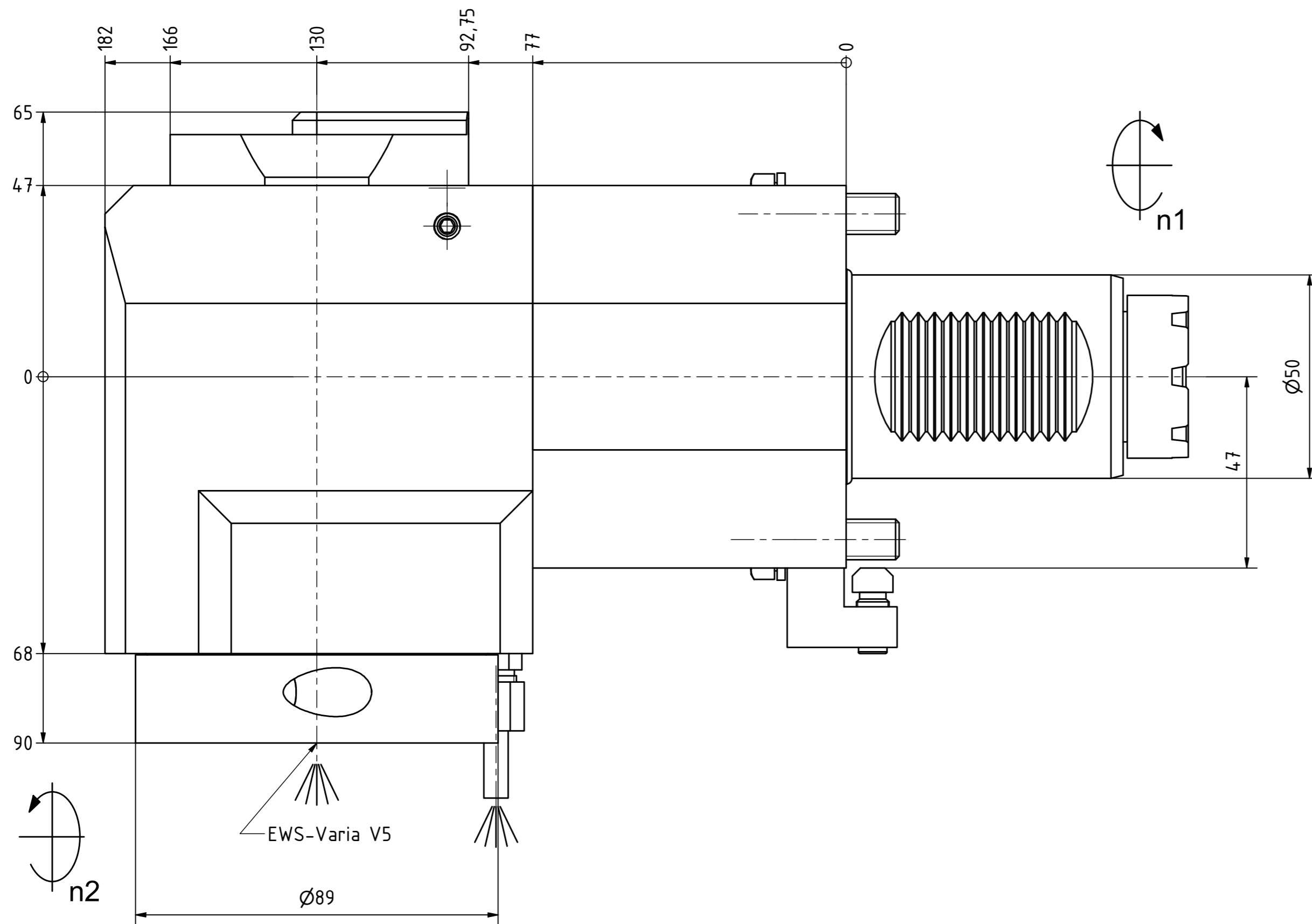
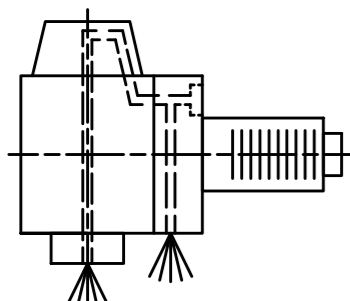
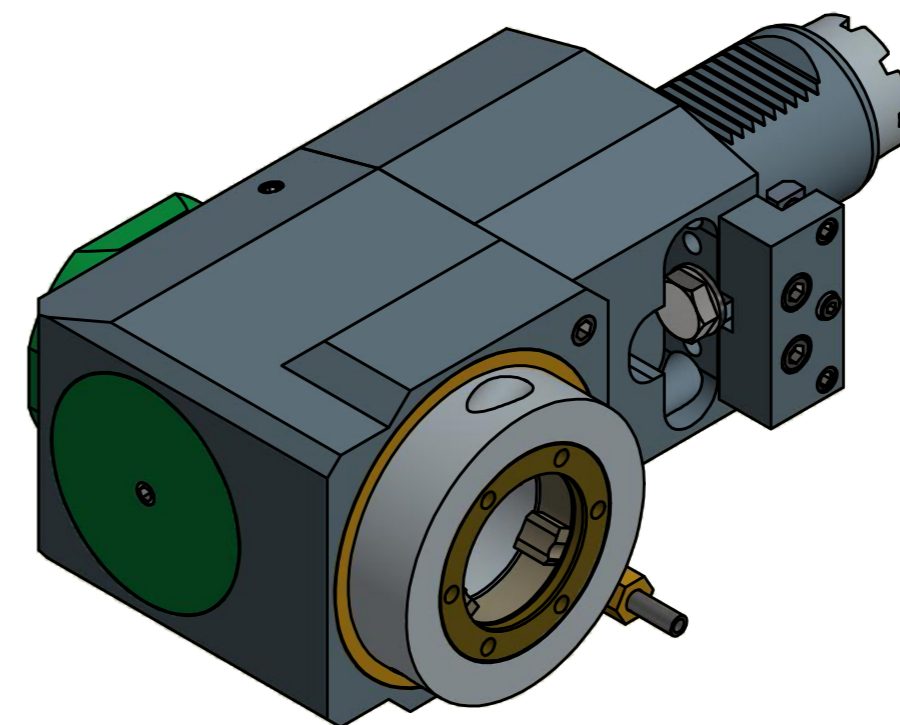

Innen- und Aussenkuehlung / Inside and outside coolant supply
 Kuehlmittelfiltrierung-50µ / coolant filtration-50µ

Bemerkung - Note	Technische Daten - technical data
Für Trockenlauf geeignet! Use without coolant fluid allowed!	Weight = 12.177 [kg]
mit Kegelrollenlager with taper roller bearing(s)	Torque max. (M1/M2) = 100 / 100 [Nm]
	Speed max. (n1/n2) = 4000 / 4000 [1/min]
	Gear ratio (i)=n1:n2 = 1:1
	Pressure (pmax) = 70 [bar]

Benennung - Title
 Radial Bohr und Fräskopf
 Radial drilling and milling head

EWS Tool Technologies	Technische Änderungen vorbehalten! Subject to technical modifications!
EWS Weigle GmbH & Co. KG Maybachstr. 1 D-73066 Uhlingen www.ews-tools.de	IDENT: D-EWS-197937
Nr. - No. 60.50V5KRT0EMRLKDX130	REV: -/- MNR. 190722

Copyright EWS Tool Technologies
 Weitergabe und Vervielfältigung dieser Unterlage,
 Verwertung und Mitteilung ihres Inhalts nicht
 gestattet, soweit nicht ausdrücklich zugestanden.
 Zuwiderhandlungen verpflichten zu Schadenersatz.

