

Schwenkbereich ±105°
Swivel area ±105°

Spannzange / collet ER25 DIN6499
Spannbereich / clamping range: 1,0 - 16,0

Gewindebohrzange / tapping collet
ET-1-25 M3-M10

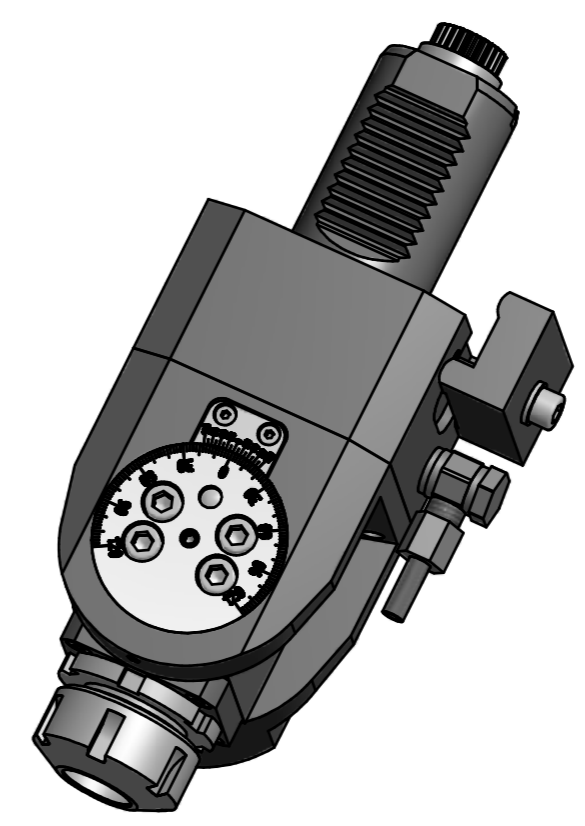
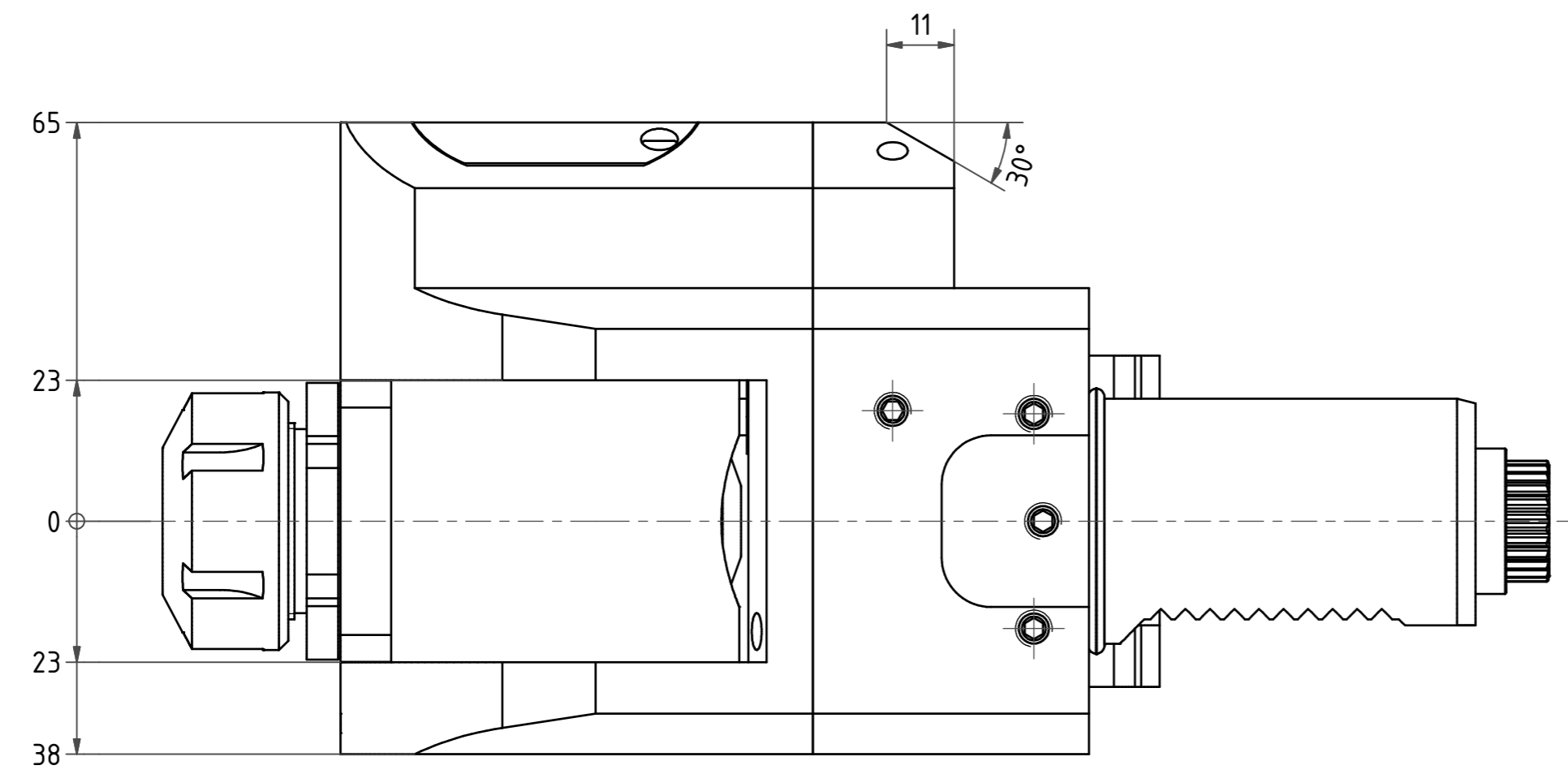
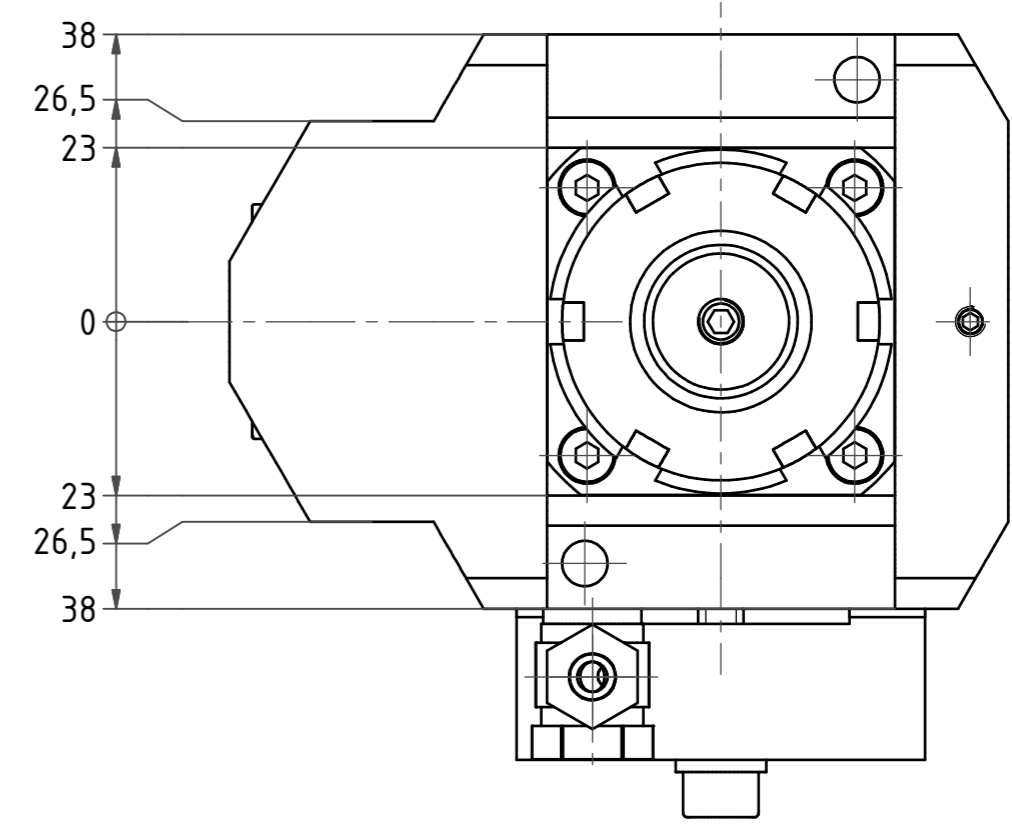
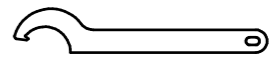

Hakenschlüssel
mit Nase
Hook wrench with
nose end
DIN1810 A 45x50

Spannzangenschlüssel
Clamping wrench
225

Copyright **EWS Tool Technologies**
Weitergabe und Vervielfältigung dieser Unterlage,
Verwertung und Mitteilung ihres Inhalts nicht
gestattet, soweit nicht ausdrücklich zugestanden.
Zuwendungen verpflichten zu Schadenersatz.

Bemerkung - Note	Technische Daten - technical data Weight = 5,728 [kg] Torque max. (M1/M2) = 20 / 20 [Nm] Speed max. (n1/n2) = 10000 / 10000 [1/min] Gear ratio (i)=n1:n2 = 1:1	Benennung - Title Schwenkkopf <i>Swivel head</i>	 EWS Weigle GmbH & Co. KG Maybachstr. 1 D-73066 Uhlringen www.ews-tools.de	Technische Änderungen vorbehalten! Subject to technical modifications! IDENT: D-EWS-202645 Nr. - No. 63.4025LD0S310	 REV: -/- MNR. 192448	
------------------	--	---	--	--	--	---