

Spannzange / collet ER25 DIN6499  
Spannbereich / clamping range: 1,0 - 16,0

Gewindebohrzange / tapping collet  
ET-1-25 M3-M10

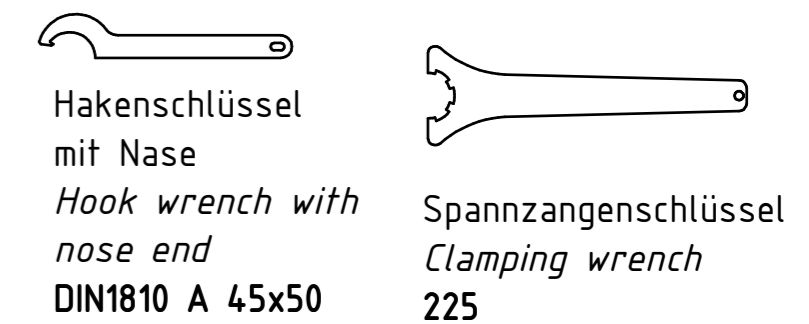
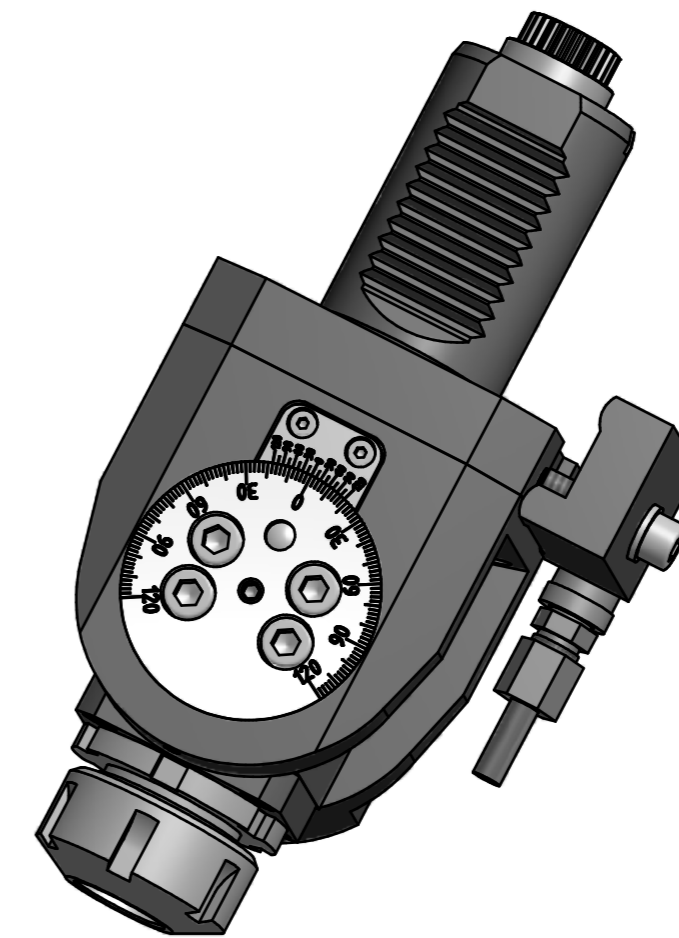
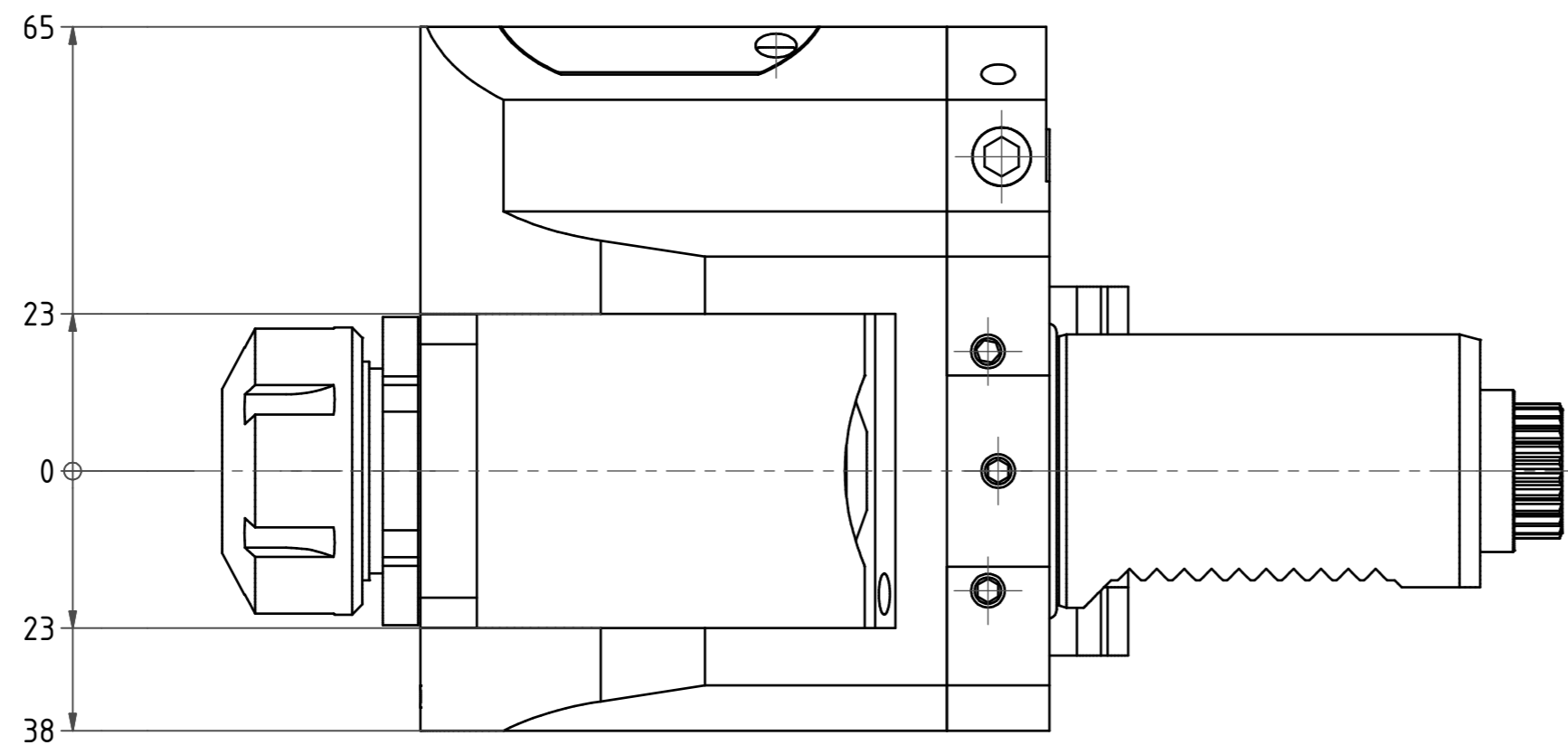

Copyright **EWS Tool Technologies**  
Weitergabe und Vervielfältigung dieser Unterlage,  
Verwertung und Mitteilung ihres Inhalts nicht  
gestattet, soweit nicht ausdrücklich zugestanden.  
Zuwendungen verpflichten zu Schadenersatz.

Bemerkung - Note	Technische Daten - technical data <b>Weight</b> = 4,442 [kg] <b>Torque max. (M1/M2)</b> = 20 / 20 [Nm] <b>Speed max. (n1/n2)</b> = 10000 / 10000 [1/min] <b>Gear ratio (i)=n1:n2</b> = 1:1	Benennung - Title <b>Schwenkkopf</b> <b>Swivel head</b>	<b>EWS</b> Tool Technologies <small>EWS Weigle GmbH &amp; Co. KG Maybachstr. 1 D-73066 Ulmringen www.ews-tools.de</small>	Technische Änderungen vorbehalten! Subject to technical modifications! IDENT: D-EWS-202654 Nr. - No. <b>63.4025D0S310</b>	MNR. REV: -/- <b>192418</b>	
------------------	--	---	--	---	-----------------------------------	--