

Spannzange / collet ER25 DIN6499
 Spannbereich / clamping range: 1,0 - 16,0

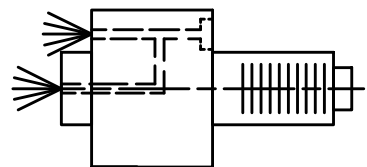

Innen- und Aussenkuehlung / Inside and outside coolant supply
 Kuehlmittelfiltrierung 50μ / coolant filtration 50μ

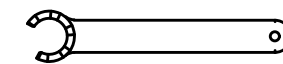
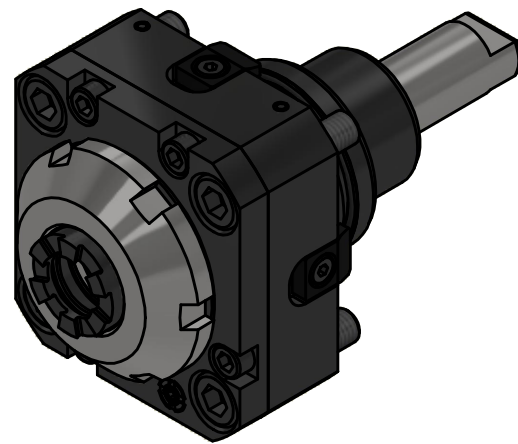

Spannzangenschlüssel für
 innenliegende Mutter
 Clamping wrench for
 internal collet
 225AX

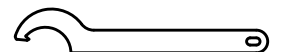

Hakenschlüssel
 mit Nase
 Hook wrench with
 nose end
 DIN1810 A 68x75

Copyright **EWS Tool Technologies**
 Weitergabe und Vervielfaeltigung dieser Unterlage,
 Verwertung und Mitteilung ihres Inhalts nicht
 gestattet, soweit nicht ausdrucklich zugestanden.
 Zuwiderhandlungen verpflichten zu Schadenersatz.

Bemerkung - Note
 Für Trockenlauf geeignet!
 Use without coolant fluid allowed!

Technische Daten - technical data
 Weight = 2.827 [kg]
 Torque max. (M1/M2) = 50 / 50 [Nm]
 Speed max. (n1/n2) = 6000 / 6000 [1/min]
 Gear ratio (i)=n1:n2 = 1:1
 Pressure (pmax) = 70 [bar]

Benennung - Title
Axial Bohr und Fräskopf
Axial drilling and milling head



Nr. - No.
40.5525VL4IKDIM-RF

Technische Aenderungen vorbehalten!
 Subject to technical modifications!
 IDENT: DEWS007161



REV: -/C

MNR.
190678

