

Spannzange / collet ER25 DIN6499
Spannbereich / clamping range: 1,0 - 16,0

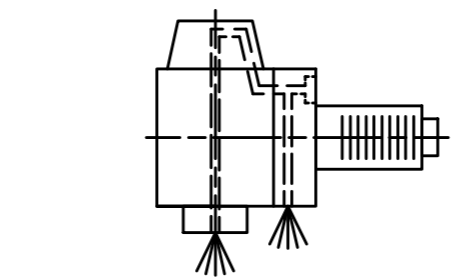

Innen- und Aussenkuehlung / Inside and outside coolant supply
Kuehlmittefiltrierung=50µ / coolant filtration=50µ

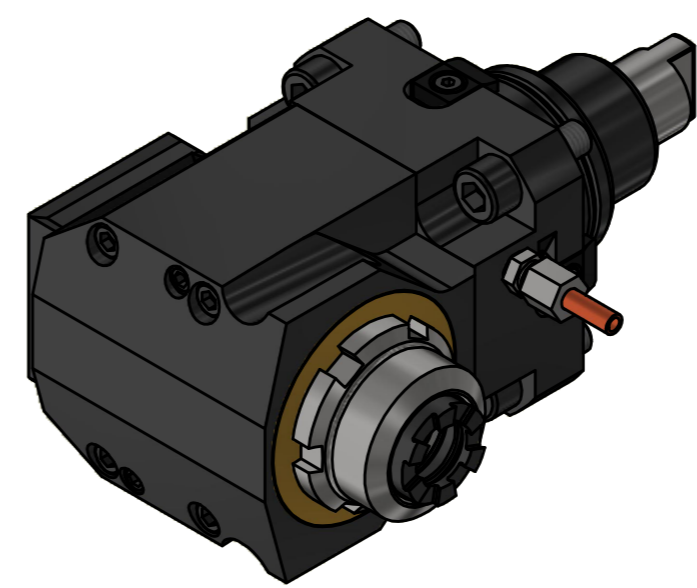
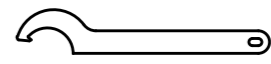

Hakenschlüssel
mit Nase
Hook wrench with
nose end
DIN1810 A 52x55

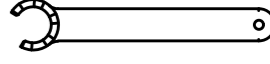
Spannzangenschlüssel für
innenliegende Mutter
Clamping wrench for
internal collet
225AX

Copyright **EWS Tool Technologies**
Weitergabe und Vervielfaeltigung dieser Unterlage,
Verwertung und Mitteilung ihres Inhalts nicht
gestattet, soweit nicht ausdrecklich zugestanden.
Zuwiderhandlungen verpflichten zu Schadenersatz.

Bemerkung - Note
Für Trockenlauf geeignet!
Use without coolant fluid allowed!

Technische Daten - technical data
Weight = 6.494 [kg]
Torque max. (M1/M2) = 50 / 50 [Nm]
Speed max. (n1/n2) = 6000 / 6000 [1/min]
Gear ratio (i)=n1:n2 = 1:1
Pressure (pmax) = 70 [bar]

Benennung - Title
Radial Bohr und Fräskopf
Radial drilling and milling head

EWS Tool Technologies EWS Weigle GmbH & Co. KG
Maybachstr. 1
D-73066 Uhingen
www.ews-tool.de
Technische Aenderungen vorbehalten!
Subject to technical modifications!
IDENT: DEWS03964S
REV: -/D
MNR.
190602

