

Spannzange / collet ER32 DIN6499  
Spannbereich / clamping range: 2,0 - 20,0

Gewindebohrzange / tapping collet  
ET-1-32 M5-M12

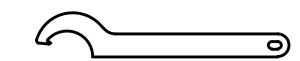

Hakenschlüssel  
mit Nase  
Hook wrench with  
nose end  
DIN1810 A 80x90

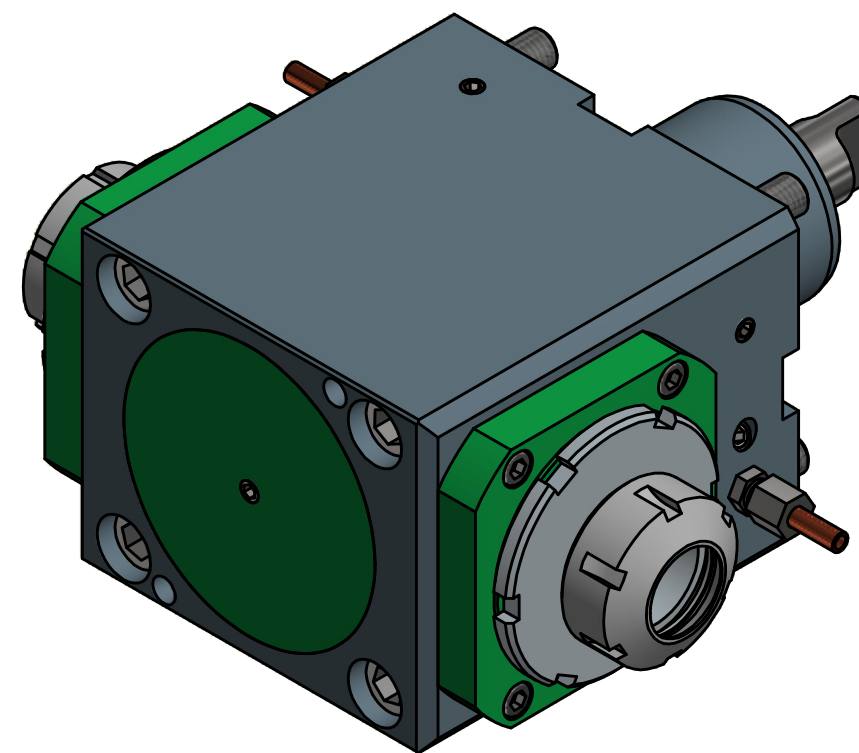

Spannzangenschlüssel  
Clamping wrench  
232

Copyright **EWS Tool Technologies**  
Weitergabe und Vervielfältigung dieser Unterlage,  
Verwertung und Mitteilung ihres Inhalts nicht  
gestattet, soweit nicht ausdrücklich zugestanden.  
Zuwendungen verpflichten zu Schadenersatz.

Bemerkung - Note

Technische Daten - technical data

Weight = 14,919 [kg]  
Torque max. (M1/M2) = 100 / 100 | 100 [Nm]  
Speed max. (n1/n2) = 10000 / 10000 | 10000 [1/min]  
Gear ratio (i)=n1:n2 = 1:1 | 1:1

Benennung - Title

Radial Bohr und Fräskopf  
Radial drilling and milling head



Nr. - No.  
60.6032DNLHSD10

Technische Änderungen vorbehalten!  
Subject to technical modifications!  
IDENT: DEWS115426

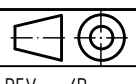

REV: -/D  
MNR.  
187423

