

 Spannzange / collet ER25 DIN6499
 Spannbereich / clamping range: 1,0 - 16,0

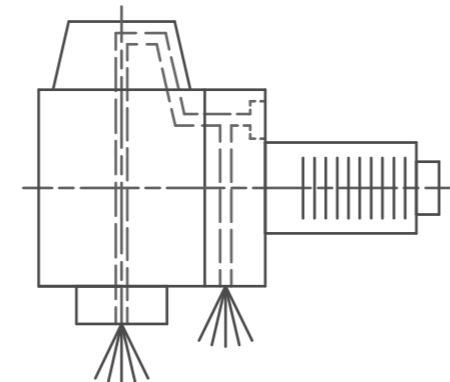

Innen- und Aussenkuehlung / Inside and outside coolant supply
 Kein Trockenlauf / No dry run
 Kuehlmittelfiltrierung <math>< 50\mu</math> / coolant filtration <math>< 50\mu</math>

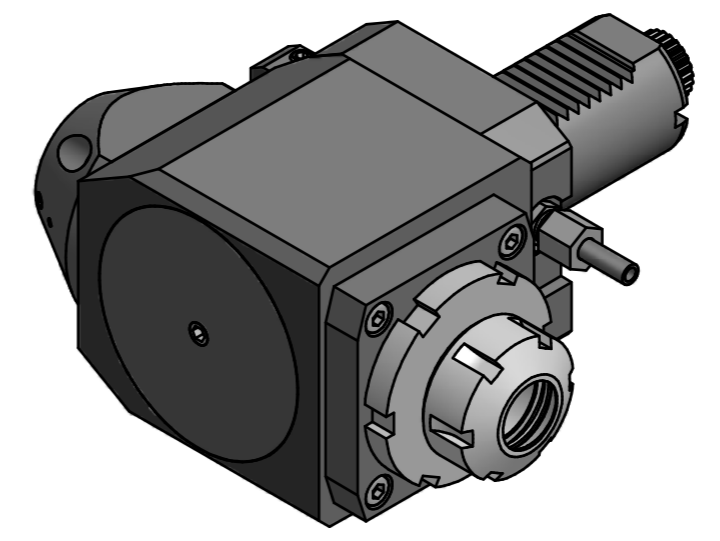

 Spannzangenschlüssel
 Clamping wrench
 225

 Hakenschlüssel
 mit Nase
 Hook wrench with
 nose end
 DIN1810 A 58x62

Copyright **EWS Tool Technologies**
 Weitergabe und Vervielfaeltigung dieser Unterlage,
 Verwertung und Mitteilung ihres Inhalts nicht
 gestattet, soweit nicht ausdruercklich zugestanden.
 Zuwiderhandlungen verpflichten zu Schadenersatz.

Bemerkung - Note Nicht ohne Kuehlmittel betreiben! Not for use without coolant-fluid!	Technische Daten - Technical data $M_1 / M_2 = 45 / 15 \text{ Nm}$ $n_1 / n_2 = 5000 / 15000 \text{ 1/min}$ $i (N_1:N_2) = 1:3$ $P_{max} = 70 \text{ bar}$	Benennung - Title Radial Bohr und Fräskopf Radial drilling and milling head	<table border="1"> <tr> <th>name</th> <th>date</th> </tr> <tr> <td>Theiss</td> <td>06.11.2015</td> </tr> </table>	name	date	Theiss	06.11.2015	Technische Aenderungen vorbehalten! Subject to technical modifications! Nr. 60.4025KCTXRIK113 MNR: 187837 IDENT: D-EWS-189889 - Blatt - page 1 (1)
name	date							
Theiss	06.11.2015							

