

Spannzange / collet ER32 DIN6499  
 Spannbereich / clamping range: 2,0 - 20,0

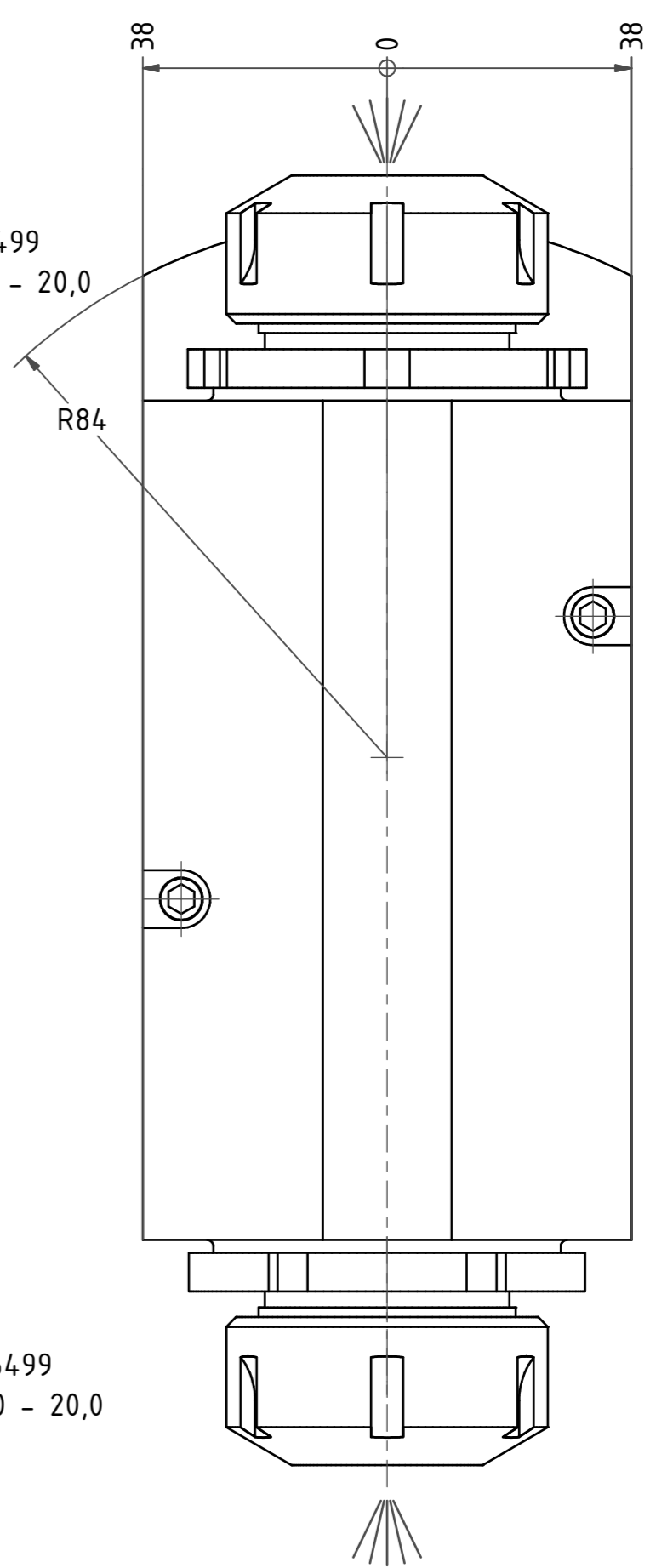

Spannzange / collet ER32 DIN6499  
 Spannbereich / clamping range: 2,0 - 20,0

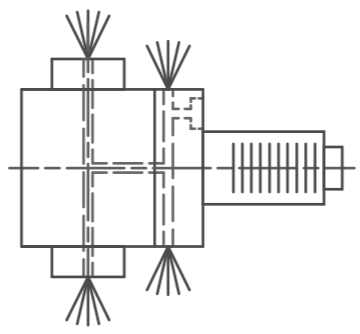
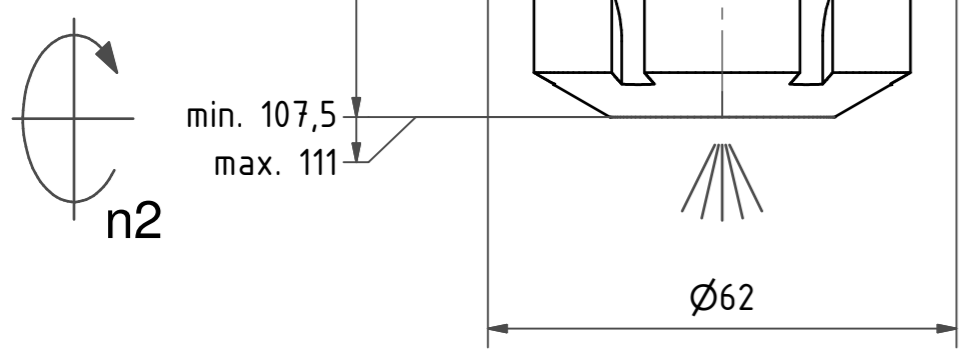

Innen- und Aussenkuehlung / Inside and outside coolant supply  
 Kein Trockenlauf / No dry run  
 Kuehlmittelfiltrierung-50µ / coolant filtration-50µ

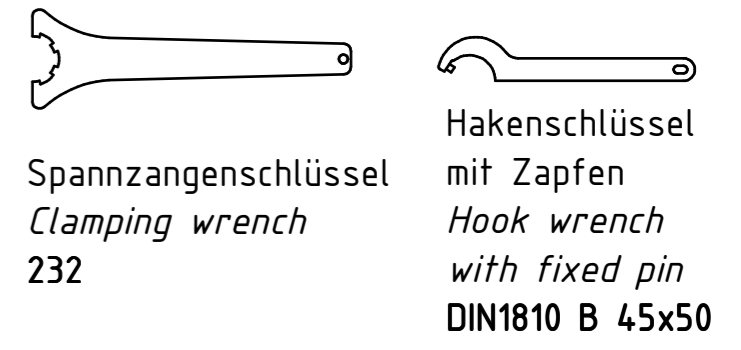
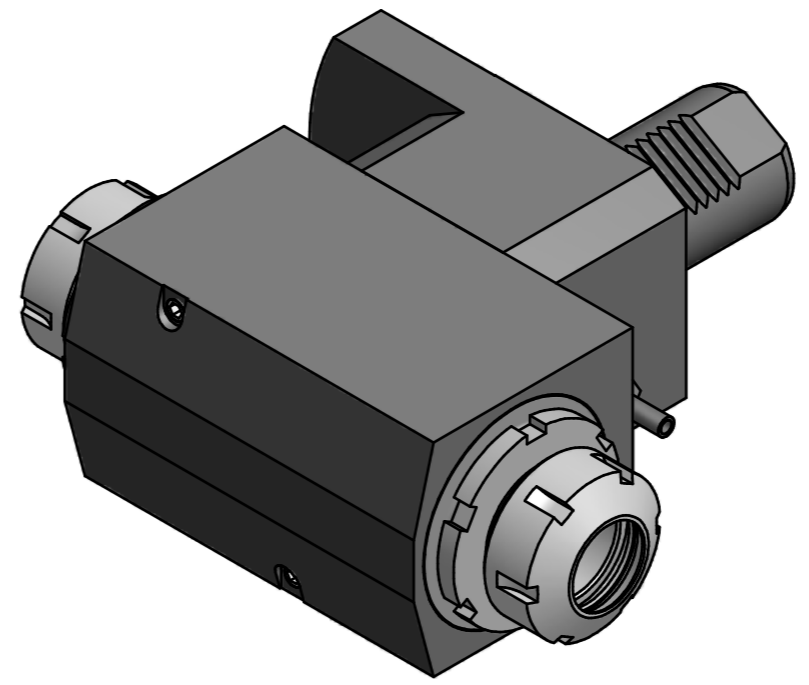

Spannzangenschlüssel  
 Clamping wrench  
 232

Hakenschlüssel  
 mit Zapfen  
 Hook wrench  
 with fixed pin  
 DIN1810 B 45x50

Copyright **EWS Tool Technologies**  
 Weitergabe und Vervielfaeltigung dieser Unterlage,  
 Verwertung und Mitteilung ihres Inhalts nicht  
 gestattet, soweit nicht ausdrecklich zugestanden.  
 Zuwiderhandlungen verpflichten zu Schadenersatz.

Bemerkung - Note Nicht ohne Kuehlmittel betreiben! Not for use without coolant-fluid!	Technische Daten - technical data <b>Weight</b> = 9,177 [kg]
	<b>Torque max.</b> (M1/M2) = 50 / 50 each Sp. [Nm]
	<b>Speed max.</b> (n1/n2) = 6000 / 6000 [1/min]
	<b>Gear ratio</b> (i)=n1:n2 = 1:1
	<b>Pressure</b> (pmax) = 25 [bar]

Benennung - Title  
**Radial Bohr und Fräskopf**  
**Radial drilling and milling head**

<b>EWS</b> Tool Technologies EWS Weigle GmbH & Co. KG Maybachstr. 1 D-73066 Uhlringen www.ews-tools.de	Technische Aenderungen vorbehalten! Subject to technical modifications! IDENT: D-EWS-179558
	Nr. - No. <b>60.4032DSQT10IKX100</b>

REV: A/-  
 MNR.  
**181968**

