

Spannzange / collet ER50 DIN6499
 Spannbereich / clamping range: 6,0 - 34,0

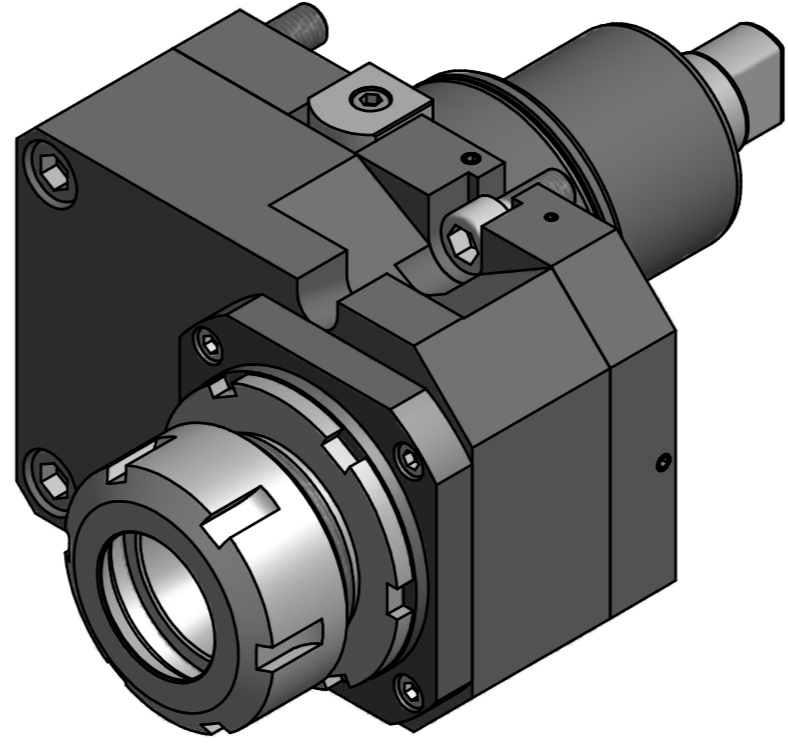
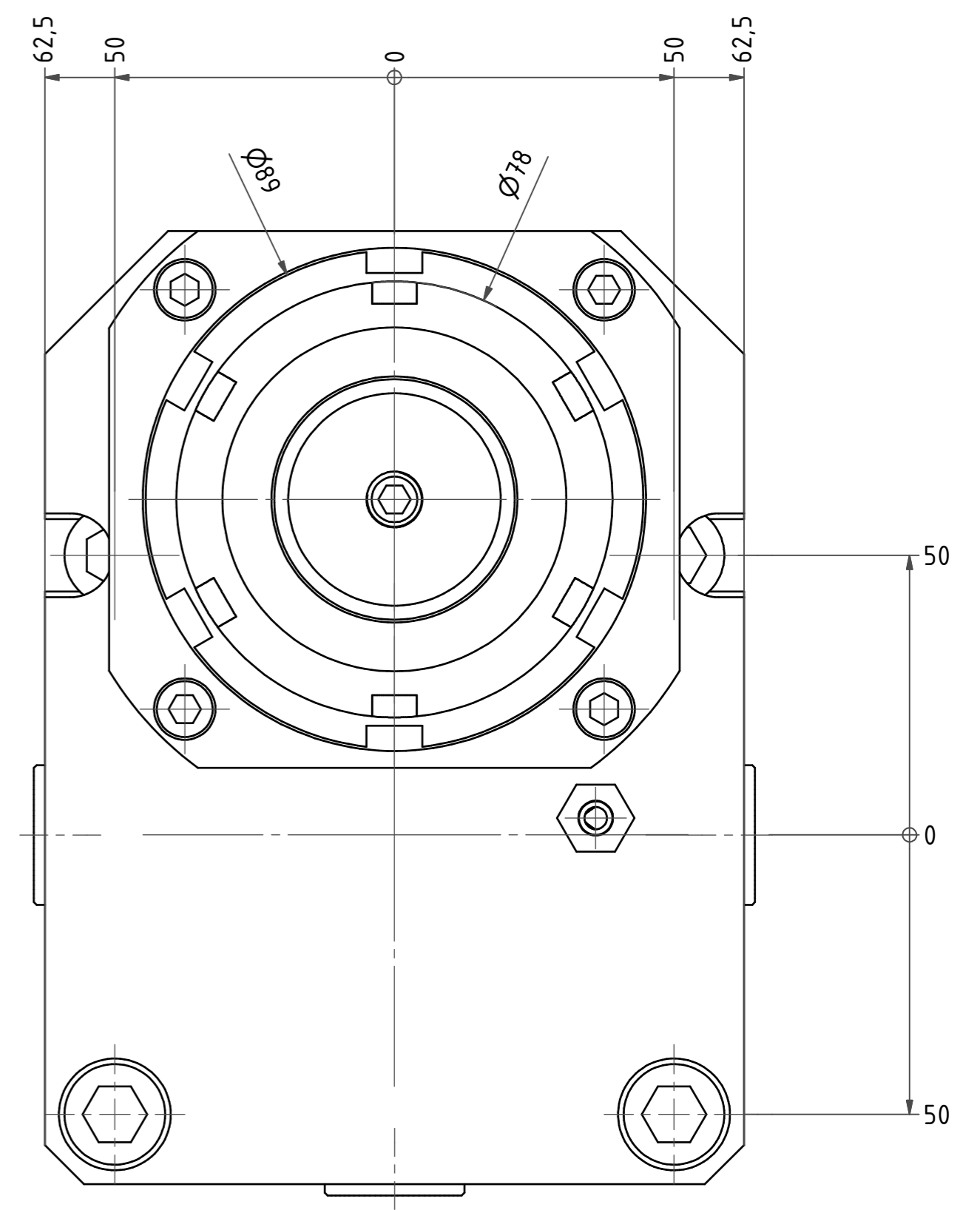
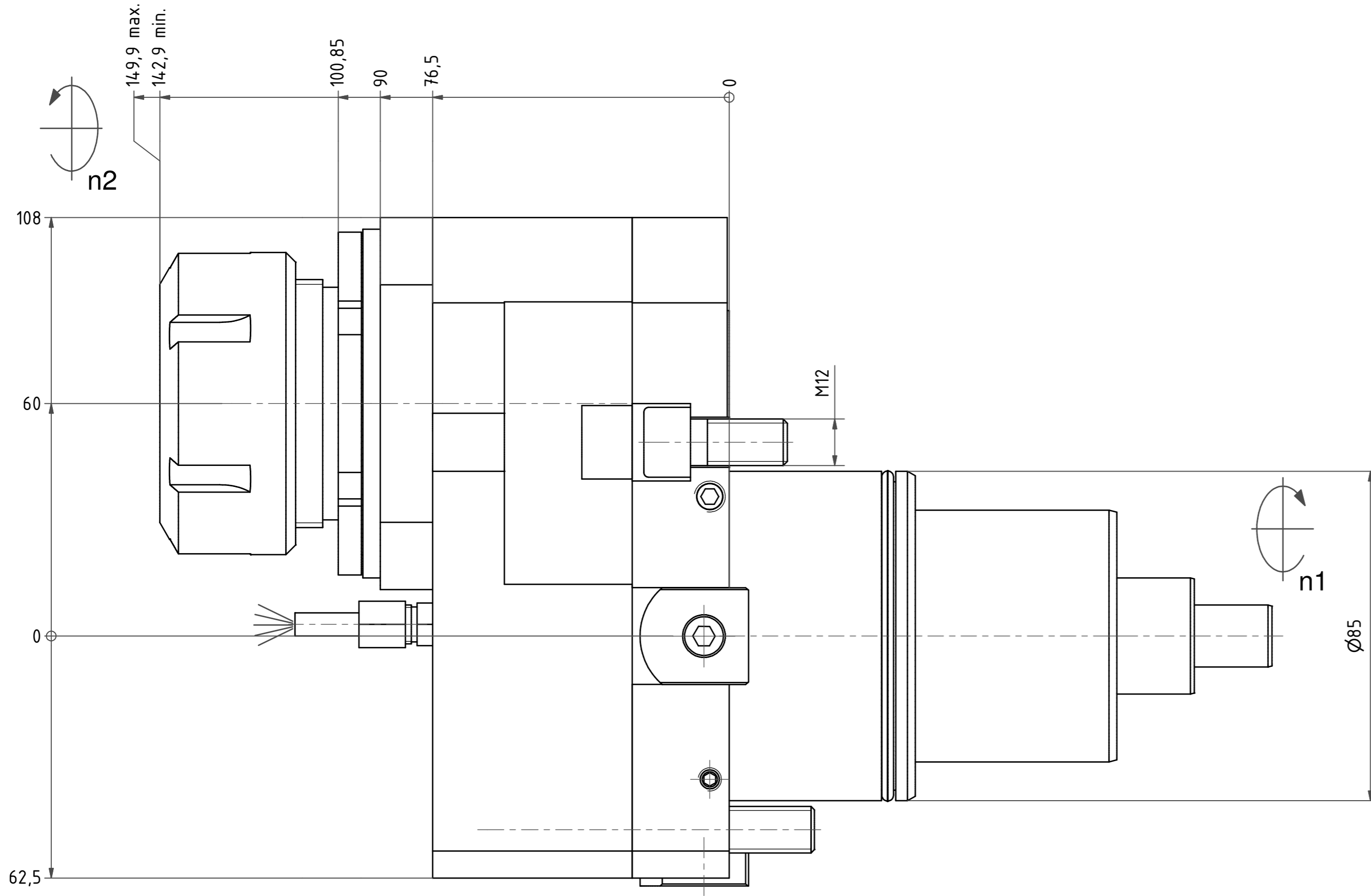

Copyright **EWS Tool Technologies**
 Weitergabe und Vervielfältigung dieser Unterlage,
 Verwertung und Mitteilung ihres Inhalts nicht
 gestattet, soweit nicht ausdrücklich zugestanden.
 Zuwiderhandlungen verpflichten zu Schadenersatz.

Bemerkung - Note mit Kegelrollenlager with taper roller bearing(s)	Technische Daten - Technical data M ₁ / M ₂ = 100 / 200 Nm n ₁ / n ₂ = 4000 / 2000 1/min i (N ₁ :N ₂) = 2:1	Benennung - Title Axial Bohr u. Fräskopf achsversetzt <i>Ax. drill. and mill. head offset</i>	name	date	Technische Änderungen vorbehalten! Subject to technical modifications!
			drawing	Lukjanow	
			Nr. 50.8550KR180912		DIN A2
			MNR: 182898 IDENT: D-EWS-182749 - Blatt - page 1 (1)		