

Spannzange / collet ER25 DIN6499
 Spannbereich / clamping range: 1,0 - 16,0

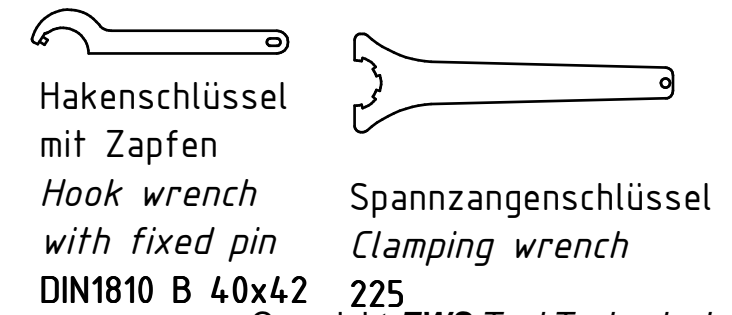

Hakenschlüssel mit Zapfen
 Hook wrench with fixed pin
 DIN1810 B 40x42 225
 Spannzangenschlüssel
 Clamping wrench
 Copyright **EWS Tool Technologies**
 Weitergabe und Vervielfältigung dieser Unterlage, Verwertung und Mitteilung ihres Inhalts nicht gestattet, soweit nicht ausdrücklich zugestanden. Zuwiderhandlungen verpflichten zu Schadenersatz.

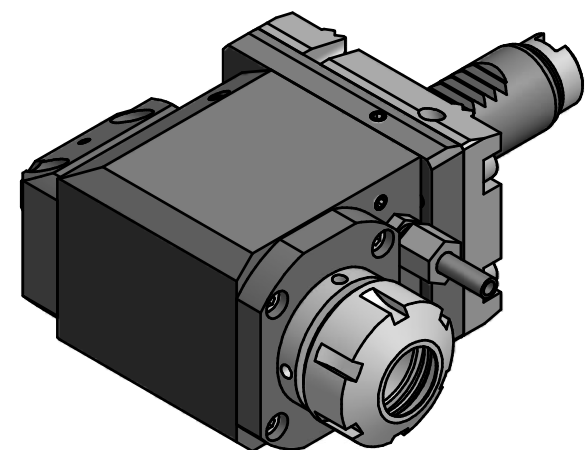
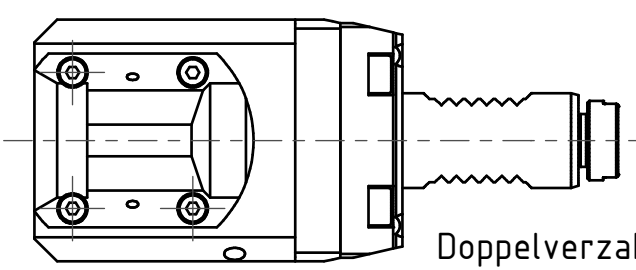

Doppelverzahnung Lizenz Traub
 double tooth system licence Traub

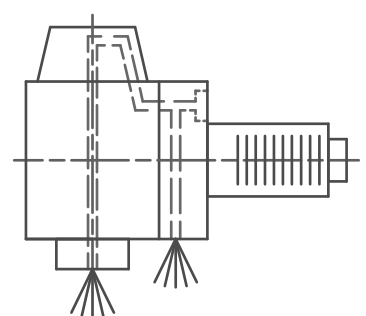

Innen- und Aussenkuehlung / Inside and outside coolant supply
 Kein Trockenlauf / No dry run
 Kuehlmittefiltrierung 50μ / coolant filtration 50μ

<p>Bemerkung - Note Nicht ohne Kuehlmitte betreiben! Not for use without coolant-fluid! mit Kegelrollenlager with taper roller bearing(s)</p>	<p>Technische Daten - technical data Weight = 3.637 [kg] Torque max. (M1/M2) = 25 / 25 [Nm] Speed max. (n1/n2) = 6000 / 6000 [1/min] Gear ratio (i)=n1:n2 = 1:1 Pressure (pmax) = 70 [bar]</p>	<p>Benennung - Title Radial Bohr und Fräskopf Radial drilling and milling head</p>	<p>EWS Tool Technologies EWS Weigle GmbH & Co. KG Maybachstr. 1 D-73066 Uhingen www.ews-tools.de</p>	<p>Technische Aenderungen vorbehalten! Subject to technical modifications! IDENT: D-EWS-183940</p>	<p>REV: -/- MNR. 183282</p>	
---	---	--	--	--	--	--