

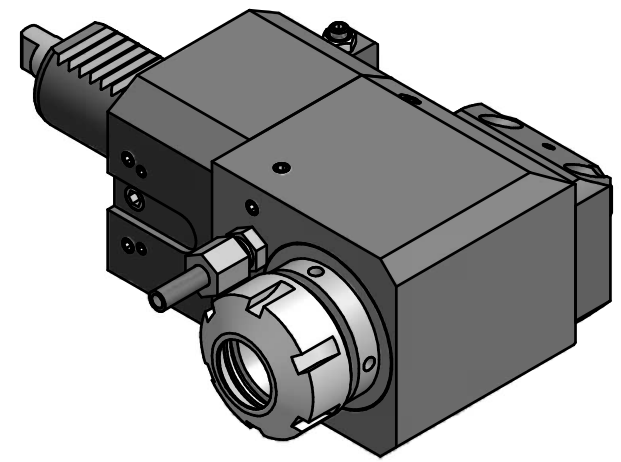

Innen- und Aussenkuehlung / Inside and outside coolant supply  
 Kein Trockenlauf / No dry run  
 Kuehlmittelfiltrierung <math>\le 50\mu</math> / coolant filtration <math>\le 50\mu</math>



  
 Hakenschlüssel  
 mit Zapfen  
 Hook wrench  
 with fixed pin  
 DIN1810 B 40x42

  
 Spannzangenschlüssel  
 Clamping wrench  
 225

Copyright **EWS Tool Technologies**  
 Weitergabe und Vervielfaeltigung dieser Unterlage,  
 Verwertung und Mitteilung ihres Inhalts nicht  
 gestattet, soweit nicht ausdruuecklich zugestanden.  
 Zuwiderhandlungen verpflichten zu Schadenersatz.

<p>Bemerkung - Note          Nicht ohne Kuehlmittel betreiben!          Not for use without coolant-fluid!</p>	<p>Technische Daten - technical data          M1 / M2 = 25 / 25 Nm          n1 / n2 = 8000 / 8000 1/min          i (N1:N2) = 1:1          pmax = 70 bar</p>	<p>Benennung - Title  <b>Radial Bohr und Fräskopf</b>  <b>Radial drilling and milling head</b></p>	<table border="1"> <tr> <th>name</th> <th>date</th> </tr> <tr> <td>Theiss</td> <td>18.03.2015</td> </tr> </table>	name	date	Theiss	18.03.2015	<p>Technische Aenderungen vorbehalten!          Subject to technical modifications!</p> <p>Nr.  <b>60.30251809LIKGLPIN48X85</b></p>	<p>DIN A3          MNR: 180769 IDENT: D-EWS-175384 A Blatt - page 1 (1)</p>
name	date								
Theiss	18.03.2015								