

Innen- und Aussenkuehlung / Inside and outside coolant supply
Kuehlmittelfiltrierung-50µ / coolant filtration-50µ

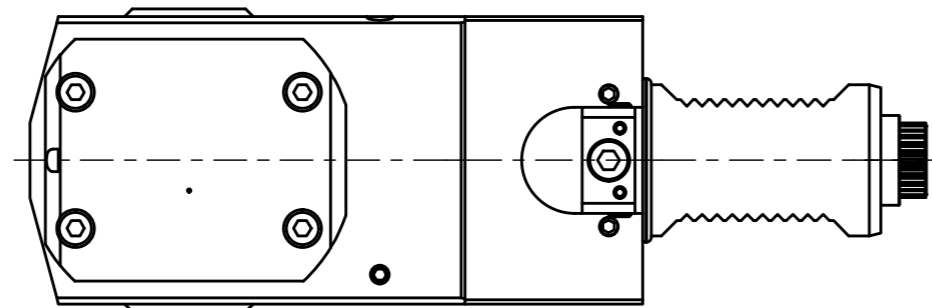

Doppelverzahnung Lizenz Traub
double tooth system licence Traub

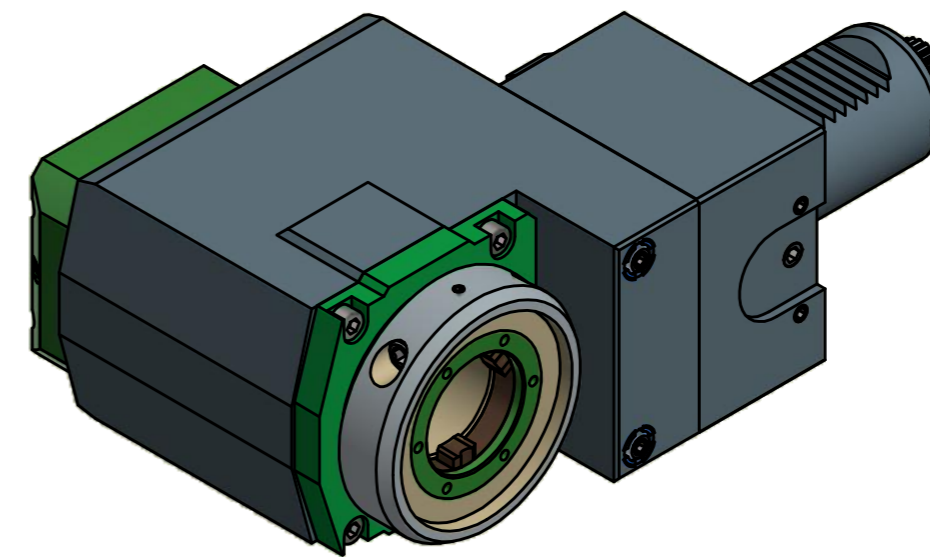

Copyright **EWS Tool Technologies**
Weitergabe und Vervielfaeltigung dieser Unterlage,
Verwertung und Mitteilung ihres Inhalts nicht
gestattet, soweit nicht ausdrecklich zugestanden.
Zuwoerhandlungen verpflichten zu Schadenersatz.

Bemerkung - Note
Für Trockenlauf geeignet!
Use without coolant fluid allowed!
mit Kegelrollenlager
with taper roller bearing(s)

Technische Daten - technical data
Weight = 9.124 [kg]
Torque max. (M1/M2) = 40 / 80 [Nm]
Speed max. (n1/n2) = 6000 / 3000 [1/min]
Gear ratio (i)=n1:n2 = 2:1
Pressure (pmax) = 70 [bar]

Benennung - Title
Radial Bohr und Fräskopf, zurückges
Radial drill. and mill. head offset

	<small>EWS Weigle GmbH & Co. KG Maybachstr. 1 D-73066 Uhlingen www.ews-tools.de</small>	Technische Aenderungen vorbehalten! Subject to technical modifications!	
		IDENT: D-EWS-178230	
Nr. - No.	80.40VX4KRLCTXRLIKDI2	MNR.	181651

