

Spannzange / collet ER40 DIN6499
 Spannbereich / clamping range: 3,0 - 26,0

Gewindebohrzange / tapping collet
 ET-1-40 M6-M16

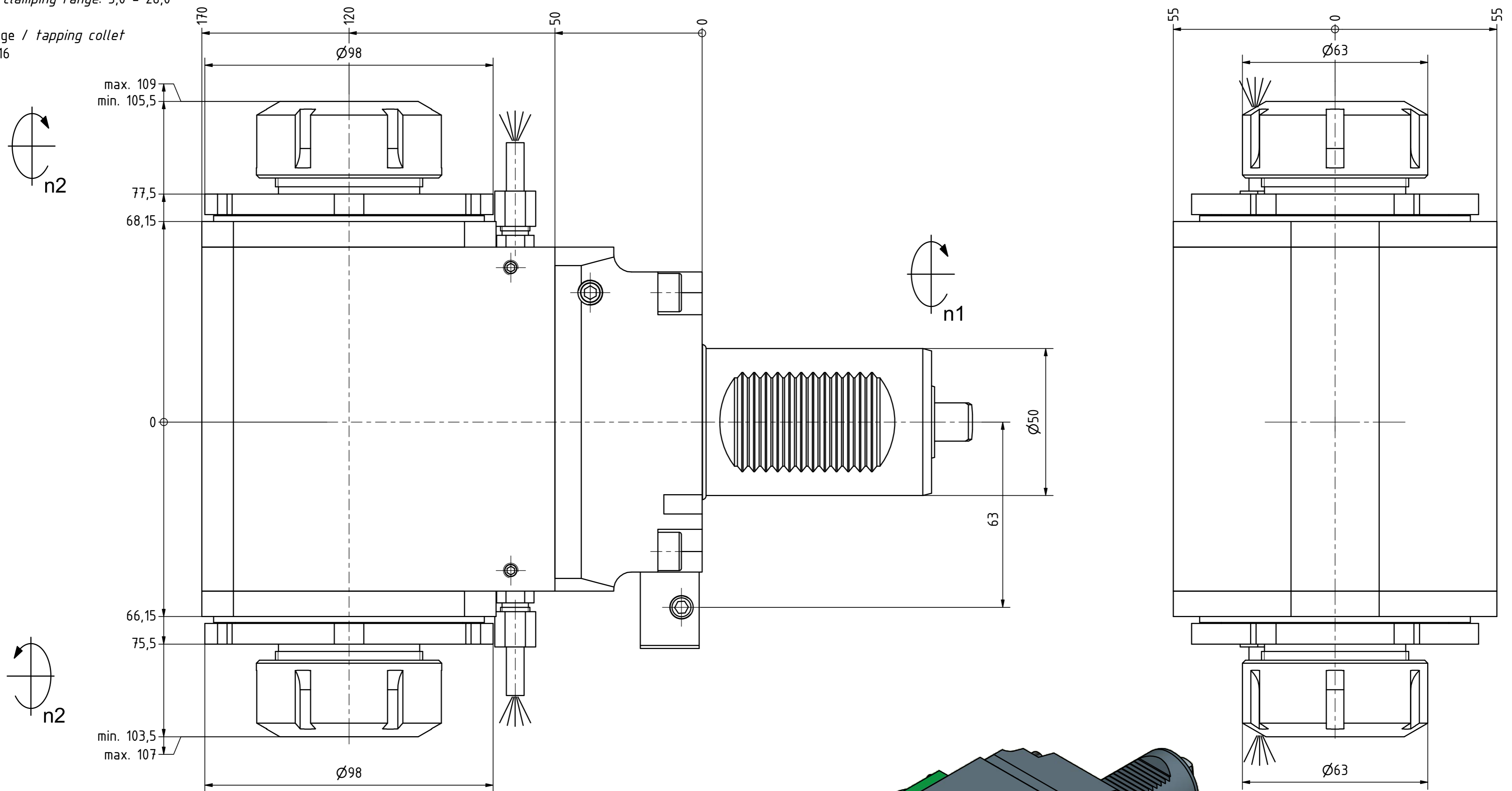

Spannzange / collet ER40 DIN6499
 Spannbereich / clamping range: 3,0 - 26,0

Gewindebohrzange / tapping collet
 ET-1-40 M6-M16

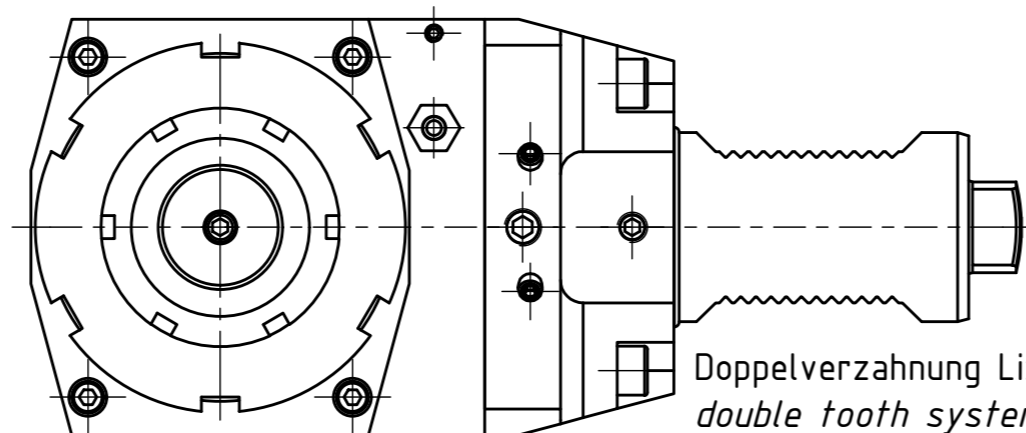

Doppelverzahnung Lizenz Traub
 double tooth system licence Traub

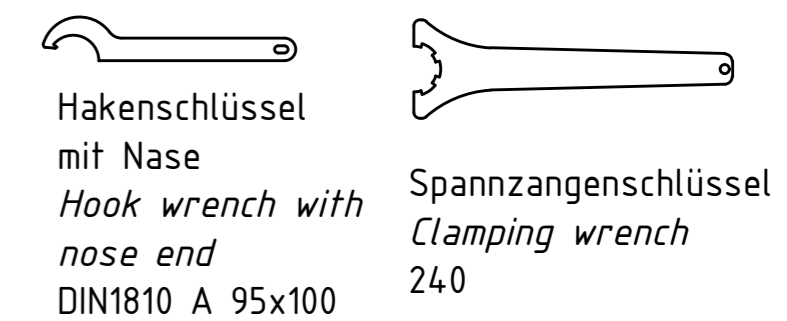
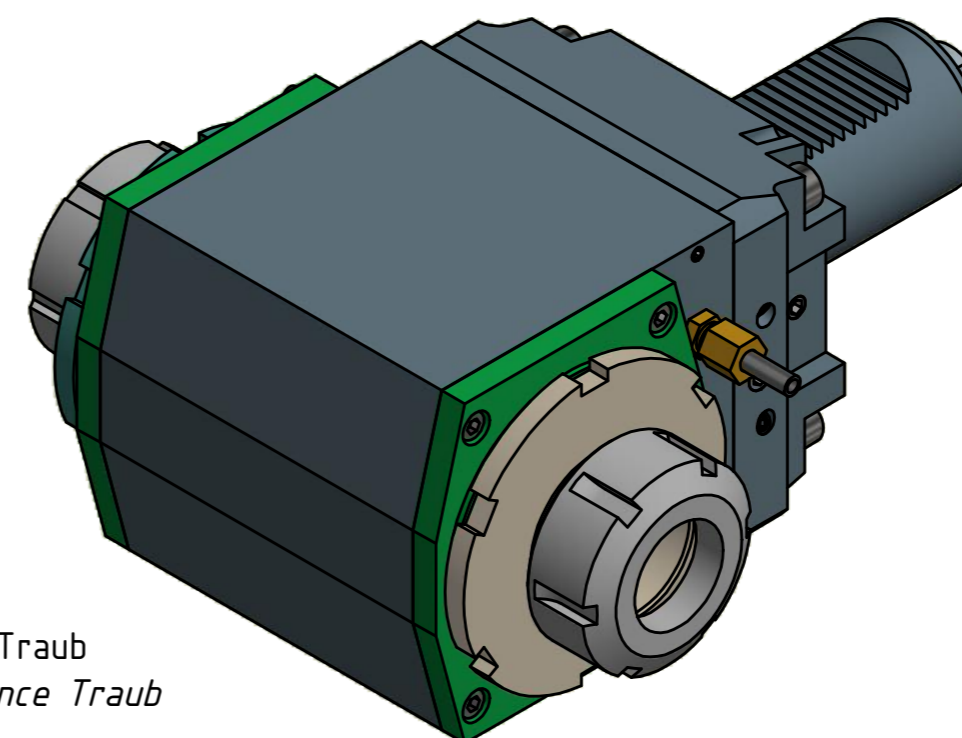

Hakenschlüssel
 mit Nase
 Hook wrench with
 nose end
 DIN1810 A 95x100

Spannzangenschlüssel
 Clamping wrench
 240

Copyright **EWS Tool Technologies**
 Weitergabe und Vervielfältigung dieser Unterlage,
 Verwertung und Mitteilung ihres Inhalts nicht
 gestattet, soweit nicht ausdrücklich zugestanden.
 Zuwiderhandlungen verpflichten zu Schadenersatz.

Bemerkung - Note	Technische Daten - technical data Weight = 17.320 [kg] Torque max. (M1/M2) = 100 / 100 100 [Nm] Speed max. (n1/n2) = 4.000/4.000 4.000 [1/min] Gear ratio (i)=n1:n2 = 1:1 1:1	Benennung - Title Radial Bohr und Fräskopf <i>Radial drilling and milling head</i>	<div style="display: flex; justify-content: space-between;"> <div data-bbox="2240 1915 2463 2047"> <p>EWS <small>EWS Weigle GmbH & Co. KG Maybachstr. 1 D-73066 Ulm/Ingen www.ews-tool.de</small></p> </div> <div data-bbox="2463 1915 2700 2047"> <p>Technische Änderungen vorbehalten! <small>Subject to technical modifications!</small></p> <p>IDENT: DEWS053227</p> </div> <div data-bbox="2700 1915 2923 2047"> <p>REV: -/A MNR. 181613</p> </div> </div> <p>Nr. - No. 60.504.0D1809RLPIN63X120</p>
------------------	---	---	---