

Spannzange / collet ER32 DIN6499  
Spannbereich / clamping range: 2,0 - 20,0

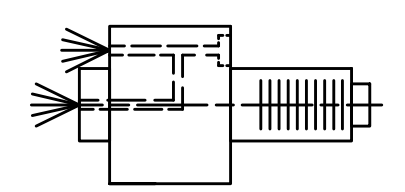
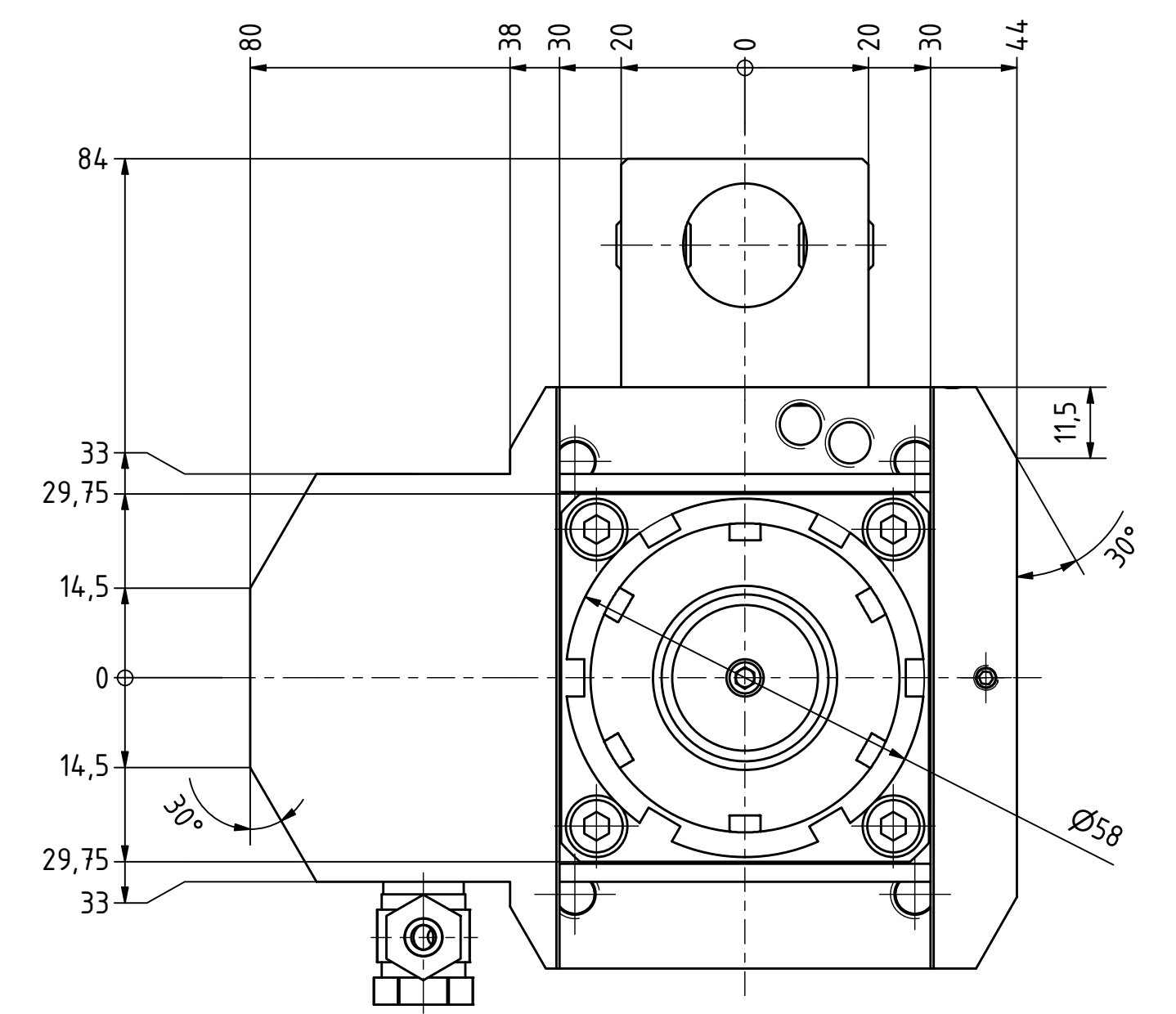
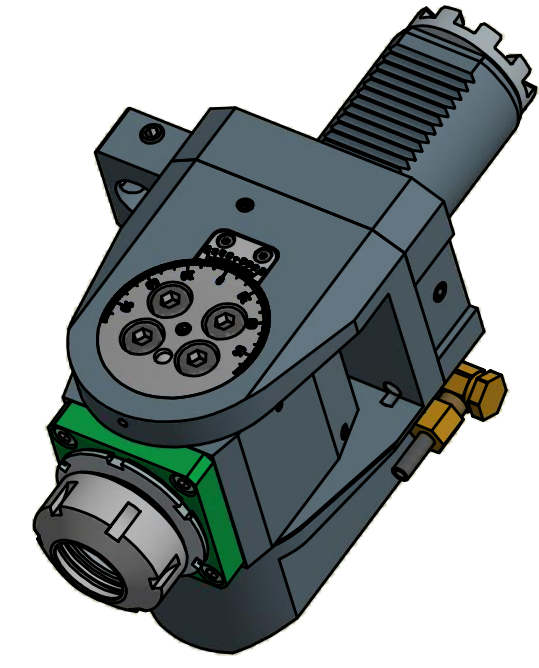

Innen- und Aussenkuehlung / Inside and outside coolant supply  
Kuehlmittelfiltrierung-50µ / coolant filtration-50µ

Hakenschlüssel mit Nase  
Hook wrench with nose end  
DIN1810 A 58x62

Spannzangenschlüssel  
Clamping wrench  
232

Bemerkung - Note Für Trockenlauf geeignet! Use without coolant fluid allowed!	Technische Daten - technical data Weight = 8,598 [kg]
	Torque max. (M1/M2) = 50 / 50 [Nm]
	Speed max. (n1/n2) = 4000 / 4000 [1/min]
	Gear ratio (i)=n1:n2 = 1:1
	Pressure (pmax) = 70 [bar]

Benennung - Title  
Schwenkkopf  
Swivel head

<b>EWS</b> Tool Technologies <small>EWS Weigle GmbH &amp; Co. KG          Maybachstr. 1          D-73066 Uhingen          www.ews-tools.de</small>	Technische Aenderungen vorbehalten! Subject to technical modifications! IDENT: D-EWS-177955	MNR. REV: -/A
	Nr. - No. 63.5032HEYIKD	181565



Copyright **EWS Tool Technologies**  
Weitergabe und Vervielfaeltigung dieser Unterlage,  
Verwertung und Mitteilung ihres Inhalts nicht  
gestattet, soweit nicht ausdrecklich zugestanden.  
Zuwiderhandlungen verpflichten zu Schadenersatz.