

Spannzange / collet ER40 DIN6499
Spannbereich / clamping range: 3,0 - 26,0

Gewindebohrzange / tapping collet
ET-1-40 M6-M16

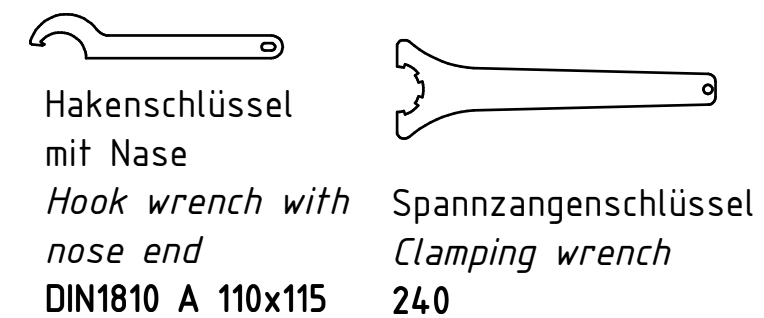

Hakenschlüssel mit Nase
Hook wrench with nose end
DIN1810 A 110x115

Spannzangenschlüssel
Clamping wrench
240

Copyright **EWS Tool Technologies**
Weitergabe und Vervielfältigung dieser Unterlage,
Verwertung und Mitteilung ihres Inhalts nicht
gestattet, soweit nicht ausdrücklich zugestanden.
Zuwerhandlungen verpflichten zu Schadenersatz.

Bemerkung - Note mit Kegelrollenlager with taper roller bearing(s)	Technische Daten - technical data M ₁ / M ₂ = 80 / 160 Nm n ₁ / n ₂ = 4000 / 2000 1/min i (N ₁ :N ₂) = 2:1	Benennung - Title Radial Bohr und Fräskopf <i>Radial drilling and milling head</i>	name	date	Technische Änderungen vorbehalten! Subject to technical modifications!	 DIN A2
			drawing	Theiss		
			 Weigelt GmbH & Co. KG Maybachstr. 1 D-73966 Uhingen Tel. +49(0)7161/93040-10		File: D-EWS-173788-.idw	Blatt - page 1 (1)