

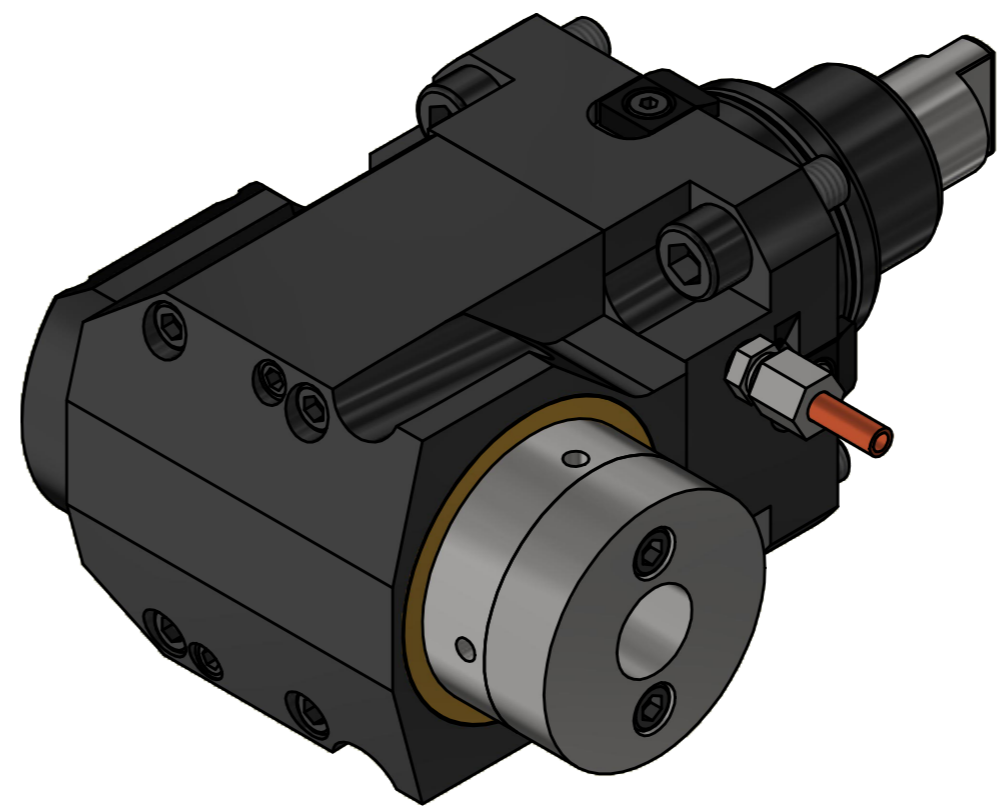

Hydrodehnfutter / *hydraulic chuck* NBC-20/25-46

Hülsen / *collets* 28.20xxHYDSP

XX (Ø) 3 4 5 6 7 8 9 10 12 14 16
 1/8 3/16 1/4 5/16 3/8 7/16 1/2 9/16 5/8



Copyright **EWS Tool Technologies**
 Weitergabe und Vervielfältigung dieser Unterlage,
 Verwertung und Mitteilung ihres Inhalts nicht
 gestattet, soweit nicht ausdrücklich zugestanden.
 Zuwiderhandlungen verpflichten zu Schadenersatz.

Bemerkung - Note	Technische Daten - technical data Weight = 6.851 [kg] Torque max. (M1/M2) = 50 / 50 [Nm] Speed max. (n1/n2) = 6000 / 6000 [1/min] Gear ratio (i)=n1:n2 = 1:1	Benennung - Title Radial Bohr und Fräskopf Radial drilling and milling head	EWS EWS Weigle GmbH & Co. KG Maybachstr. 1 D-73066 Uhlingen www.ews-tool.de	Technische Änderungen vorbehalten! Subject to technical modifications! IDENT: DEWS005886 MNR. REV: -/C	
			Nr. - No. 60.5520HYDVL2	MNR. 179273	