

EWS-Varia VX3

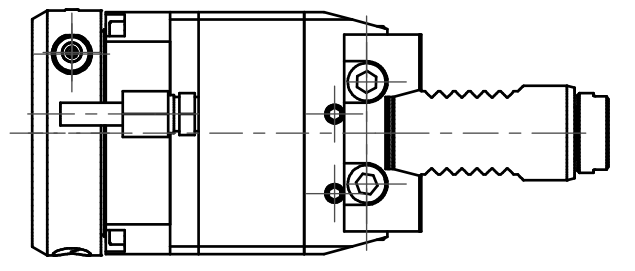

Doppelverzahnung Lizenz Traub
double tooth system licence Traub

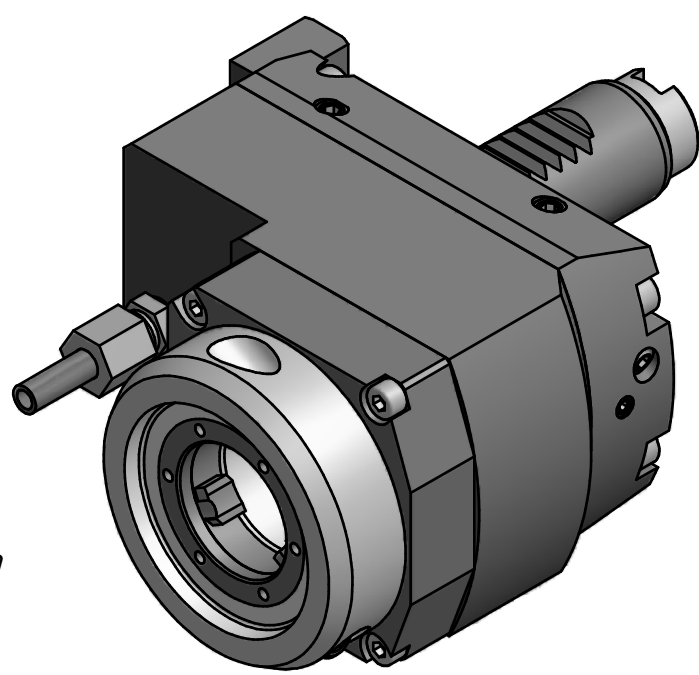

Copyright **EWS Tool Technologies**
Weitergabe und Vervielfaeltigung dieser Unterlage,
Verwertung und Mitteilung ihres Inhalts nicht
gestattet, soweit nicht ausdrecklich zugestanden.
Zuwiderhandlungen verpflichten zu Schadenersatz.

Bemerkung - Note 	Technische Daten - technical data $M_1 / M_2 = 20 / 40 \text{ Nm}$ $n_1 / n_2 = 6000 / 3000 \text{ 1/min}$ $i (N_1:N_2) = 2:1$	Benennung - Title Axial Bohr u. Fräskopf achsversetzt Ax. drill. and mill. head offset	<table border="1"> <thead> <tr> <th>name</th> <th>date</th> </tr> </thead> <tbody> <tr> <td>Theiss</td> <td>08.01.2015</td> </tr> </tbody> </table>	name	date	Theiss	08.01.2015	Technische Aenderungen vorbehalten! Subject to technical modifications! Nr. 50.25VX3G200RLI2V MNR: 179236 IDENT: D-EWS-170872 - Blatt - page 1 (1)
name	date							
Theiss	08.01.2015							

