

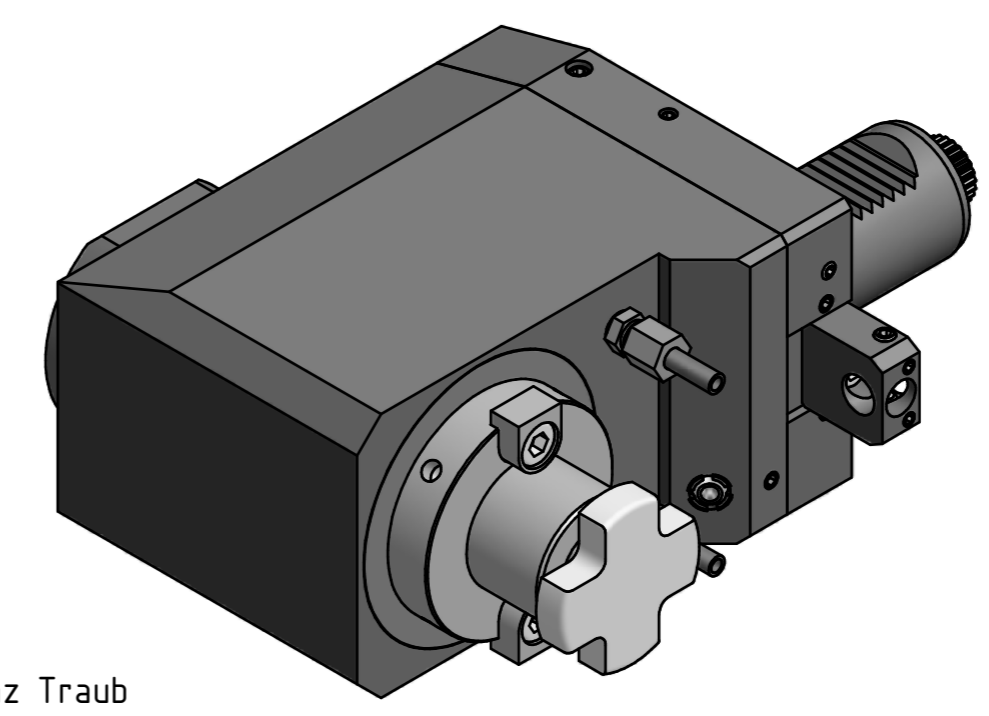

Doppelverzahnung Lizenz Traub
double tooth system licence Traub



Hakenschlüssel
mit Zapfen
Hook wrench
with fixed pin
DIN1810 B 58x62

Copyright **EWS Tool Technologies**
Weitergabe und Vervielfältigung dieser Unterlage,
Verwertung und Mitteilung ihres Inhalts nicht
gestattet, soweit nicht ausdrücklich zugestanden.
Zuwendungen verpflichten zu Schadenersatz.

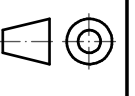
Bemerkung - Note mit Kegelrollenlager with taper roller bearing(s)	Technische Daten - technical data M ₁ / M ₂ = 40 / 120 Nm n ₁ / n ₂ = 6000 / 2000 1/min i (N ₁ :N ₂) = 2,878:1	Benennung - Title Radial Fräskopf, zurückgesetzt Radial milling head offset	name	date	Technische Änderungen vorbehalten! Subject to technical modifications!	
			drawing	Theiss		25.11.2014
			 Weigelt GmbH & Co. KG Maybachstr. 1 D-73966 Ulmengen Tel. +49(0)7161/93040-10		Nr. 82.4040KRLCTXRLI3	 Blatt - page 1 (1)
			File: D-EWS-168584-ldw			