

EWS-Varia V5

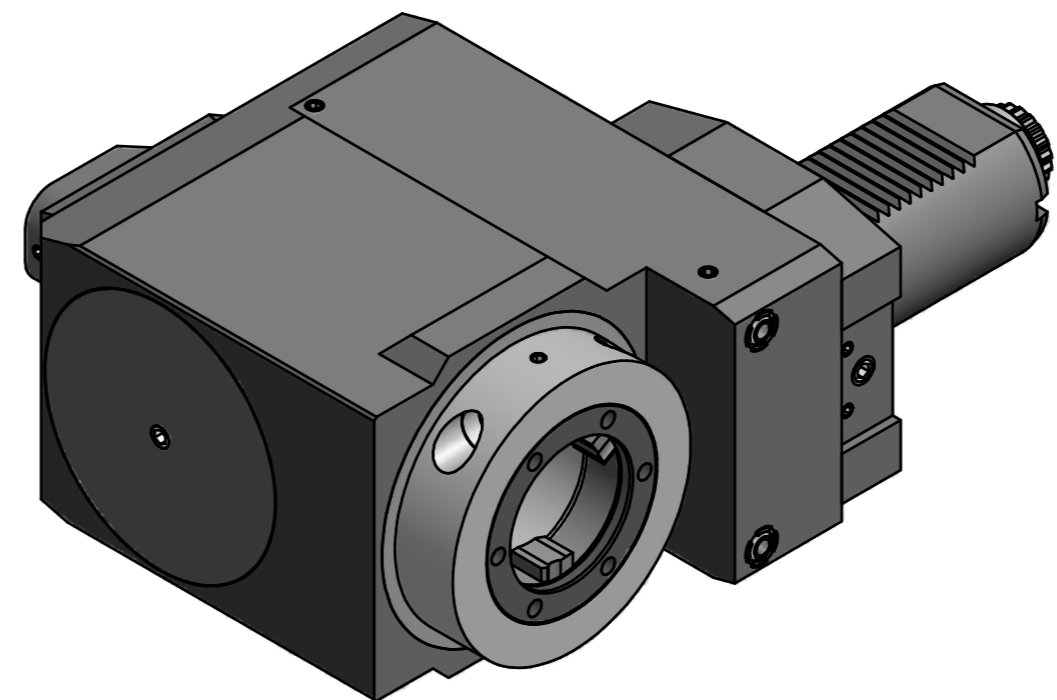
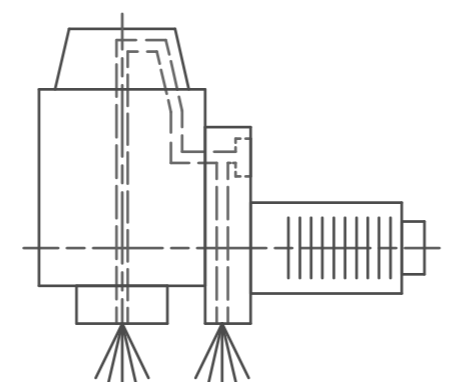

Innen- und Aussenkuehlung / Inside and outside coolant supply
 Kein Trockenlauf / No dry run
 Kuehlmittelfiltrierung 50μ / coolant filtration 50μ

Copyright **EWS Tool Technologies**
 Weitergabe und Vervielfaeltigung dieser Unterlage,
 Verwertung und Mitteilung ihres Inhalts nicht
 gestattet, soweit nicht ausdruercklich zugestanden.
 Zuwiderhandlungen verpflichten zu Schadenersatz.

Bemerkung - Note Nicht ohne Kuehlmittel betreiben! Not for use without coolant-fluid!	Technische Daten - Technical data $M_1 / M_2 = 100 / 50 \text{ Nm}$ $n_1 / n_2 = 4000 / 8000 \text{ 1/min}$ $i (N_1:N_2) = 1:2$ $P_{max} = 70 \text{ bar}$	Benennung - Title Radial Bohr und Fräskopf, zurückges Radial drill. and mill. head offset	name Theiss	date 05.11.2014	Technische Aenderungen vorbehalten! Subject to technical modifications! Nr. 80.50V554.80RIK11 File: D-EWS-167029-.idw	Waisige GmbH & Co. KG Maybachstr. 1 D-73066 Ullingen Tel. +49(0)7161/93040-10	DIN A2 Blatt - page 1 (1)
			drawing Theiss				