

Spannzange / collet ER20 DIN6499
 Spannungsbereich / clamping range: 1,0 - 13,0

Gewindebohrzange / tapping collet
 ET-1-20 M2-M6

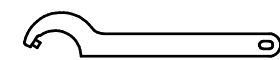

Hakenschlüssel
 mit Zapfen
 Hook wrench
 with fixed pin
 DIN1810 B 40x42

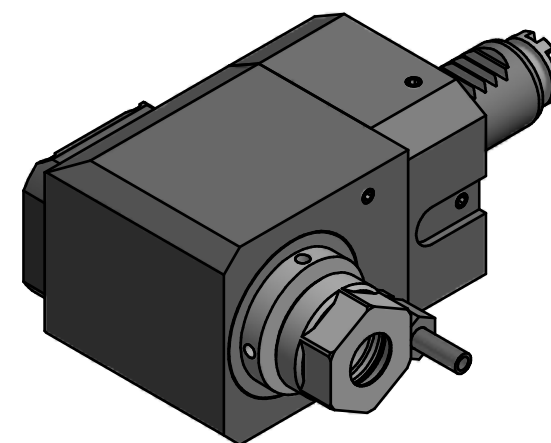
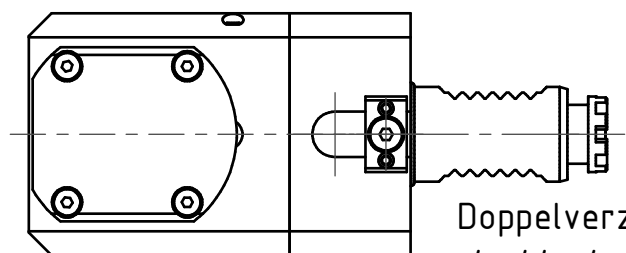

Doppelverzahnung Lizenz Traub
 double tooth system licence Traub

Copyright **EWS Tool Technologies**
 Weitergabe und Vervielfältigung dieser Unterlage,
 Verwertung und Mitteilung ihres Inhalts nicht
 gestattet, soweit nicht ausdrücklich zugestanden.
 Zuwiderhandlungen verpflichten zu Schadenersatz.

Bemerkung - Note

Technische Daten - technical data

Weight = 3.172 [kg]
 Torque max. (M1/M2) = 24 / 12 [Nm]
 Speed max. (n1/n2) = 6000 / 12000 [1/min]
 Gear ratio (i)=n1:n2 = 1:2

Benennung - Title

Radial Bohr und Fräskopf
 Radial drilling and milling head



Nr. - No.
 60.2520BSARLI1

Technische Änderungen vorbehalten!
 Subject to technical modifications!

IDENT: D-EWS-166102



REV: -/-

MNR.

177976

