

Fraeserwelle austauschbar  
Spindle removable

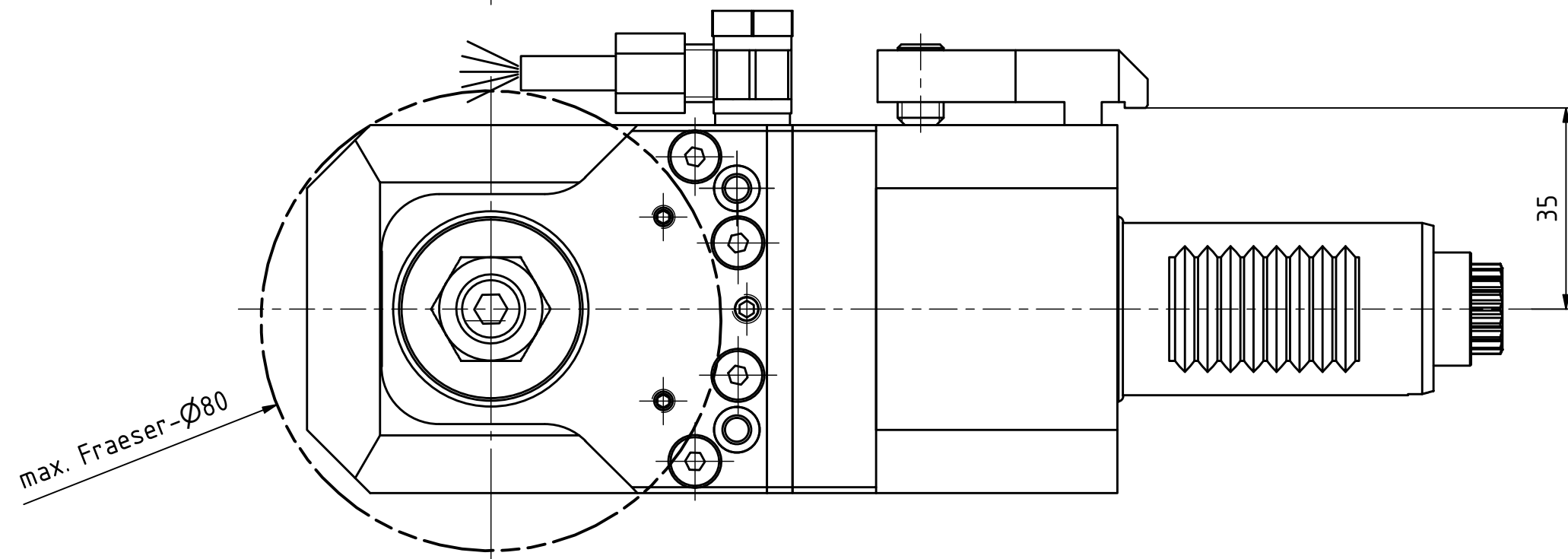
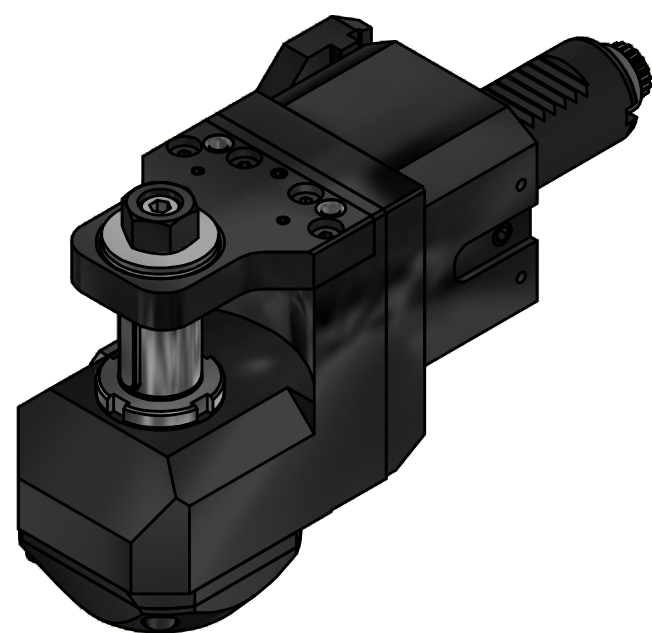
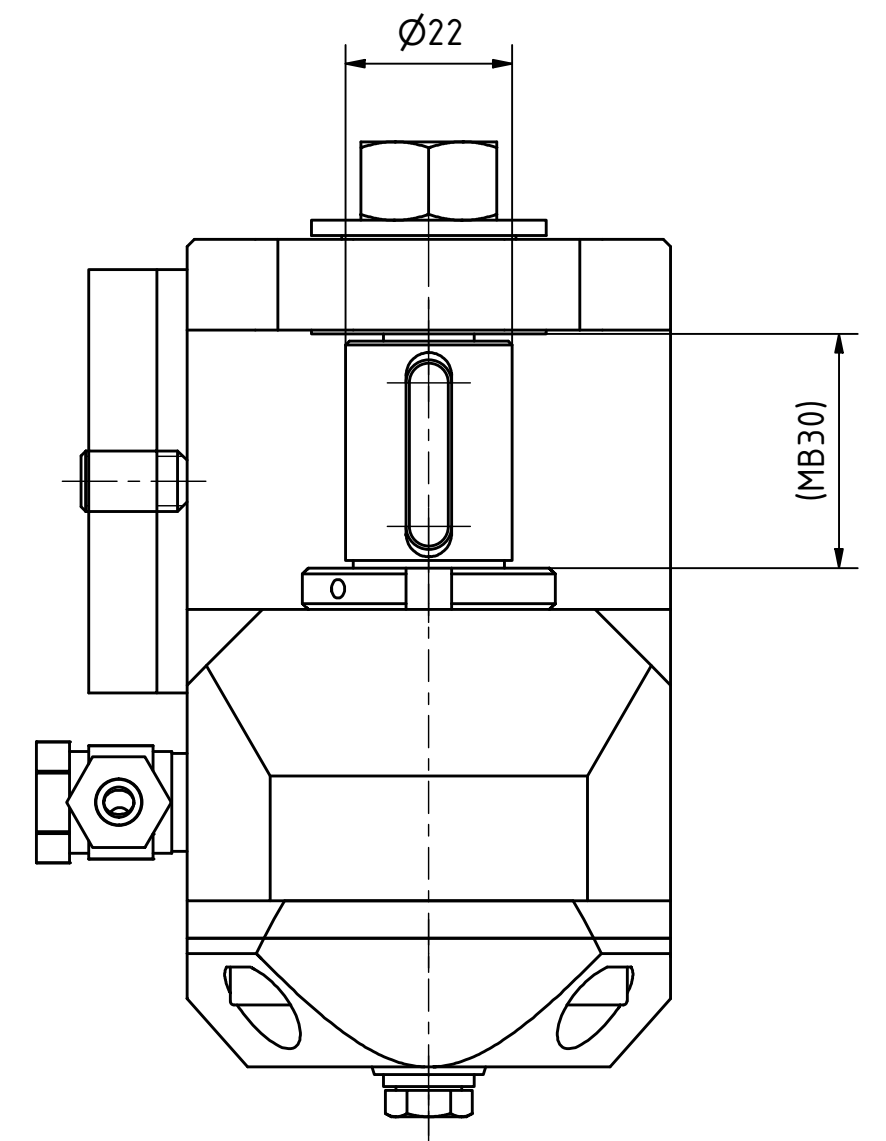
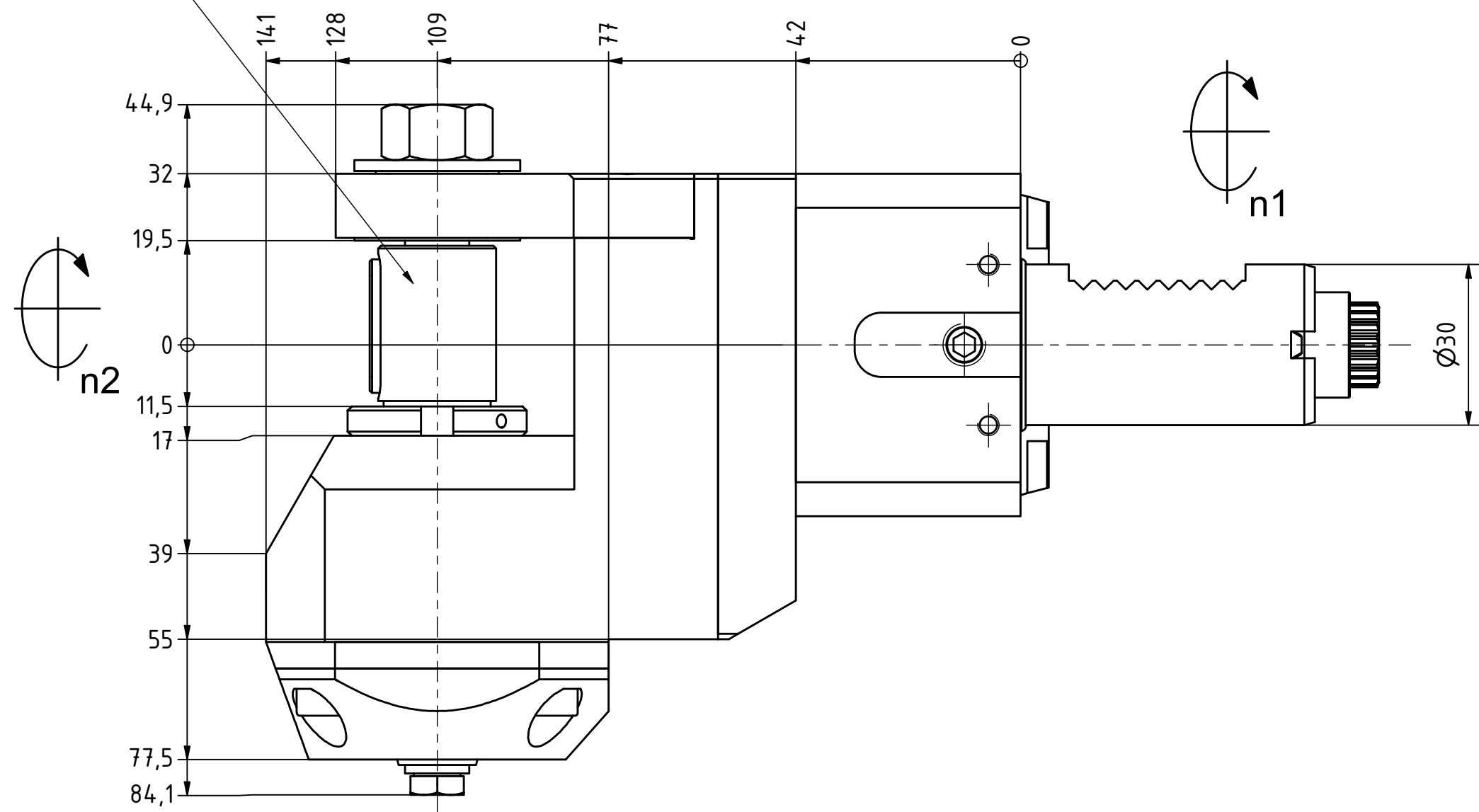
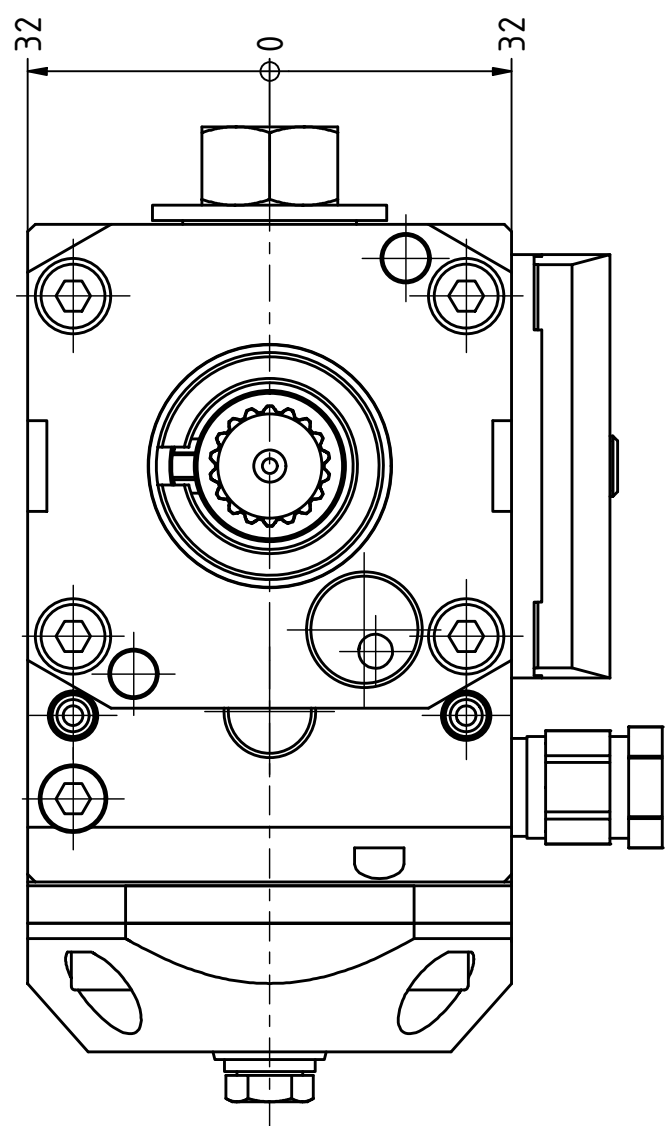

Copyright **EWS Tool Technologies**  
Weitergabe und Vervielfältigung dieser Unterlage,  
Verwertung und Mitteilung ihres Inhalts nicht  
gestattet, soweit nicht ausdrücklich zugestanden.  
Zuwerhandlungen verpflichten zu Schadenersatz.

Bemerkung - Note 	Technische Daten - technical data <b>Weight</b> = 4,745 [kg] <b>Torque max. (M1/M2)</b> = 20 / 60 [Nm] <b>Speed max. (n1/n2)</b> = 6000 / 2000 [1/min] <b>Gear ratio (i)=n1:n2</b> = 3:1	Benennung - Title <b>Scheibenfräserkopf</b> <b>Radial saw milling head</b>	<b>EWS</b> EWS Weigle GmbH & Co. KG Maybachstr. 1 D-73066 Uhlingen www.ews-tools.de Nr. - No. <b>64.3022LE365I3EL</b>	Technische Änderungen vorbehalten! Subject to technical modifications! IDENT: D-EWS-165559 MNR. <b>177833</b>	
----------------------	--	--	--	---	---