

EWS.Varia

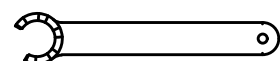

Tech
Details

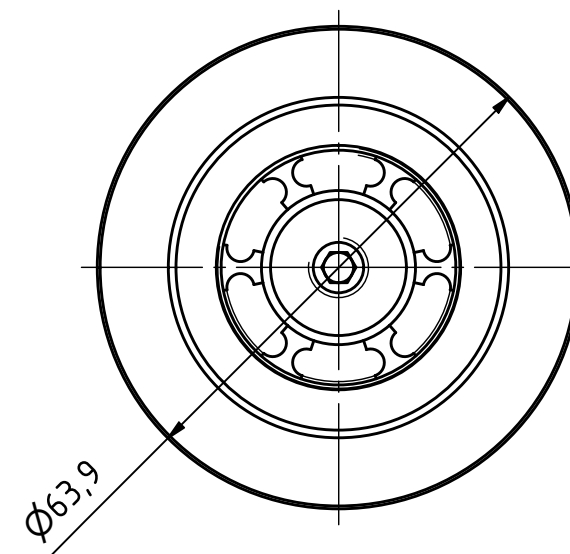
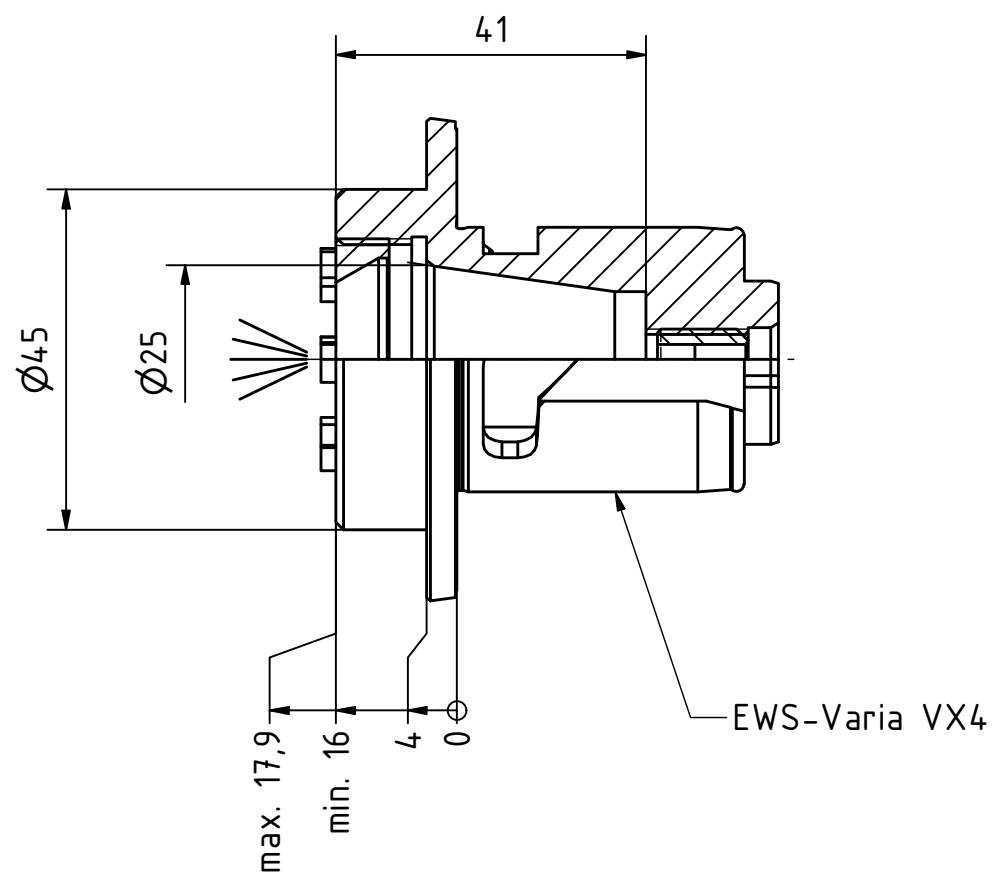

Spannzangenschlüssel für
innenliegende Mutter
*Clamping wrench for
internal collet*
225AX

Spannzange / collet ER25 DIN6499
Spannbereich / clamping range: 1,0 - 16,0

Gewindebohrzange / tapping collet
ET-1-25 M3-M12

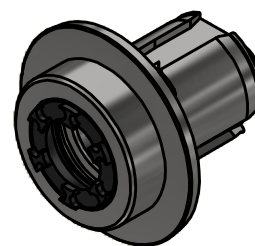

Copyright **EWS Tool Technologies**
Weitergabe und Vervielfältigung dieser Unterlage,
Verwertung und Mitteilung ihres Inhalts nicht
gestattet, soweit nicht ausdrücklich zugestanden.
Zu widerhandlungen verpflichten zu Schadenersatz.

Bemerkung - Note

Schutzrecht angemeldet
Trademark right applied

Technische Daten - technical data

Weight = 0.475 [kg]

Benennung - Title

Spannzangenaufnahme
Collet chuck holder



EWS Weigle GmbH & Co. KG
Maybachstr. 1
D-73066 Uhingen
www.ews-tools.de

Technische Änderungen vorbehalten!
Subject to technical modifications!

IDENT: DEWS234396



REV: -/B

Nr. - No.

31.VX425IML16

MNR.

177341

