

Spannzange / collet ER32 DIN6499
 Spannbereich / clamping range: 2,0 - 20,0

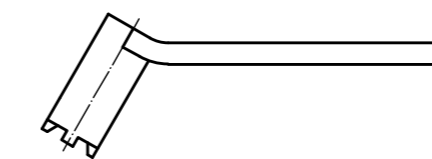

Schlüssel für Ausrichtung
 im Lieferumfang enthalten.
 Wrench for adjustment
 included in delivery
 AZS-LT2000

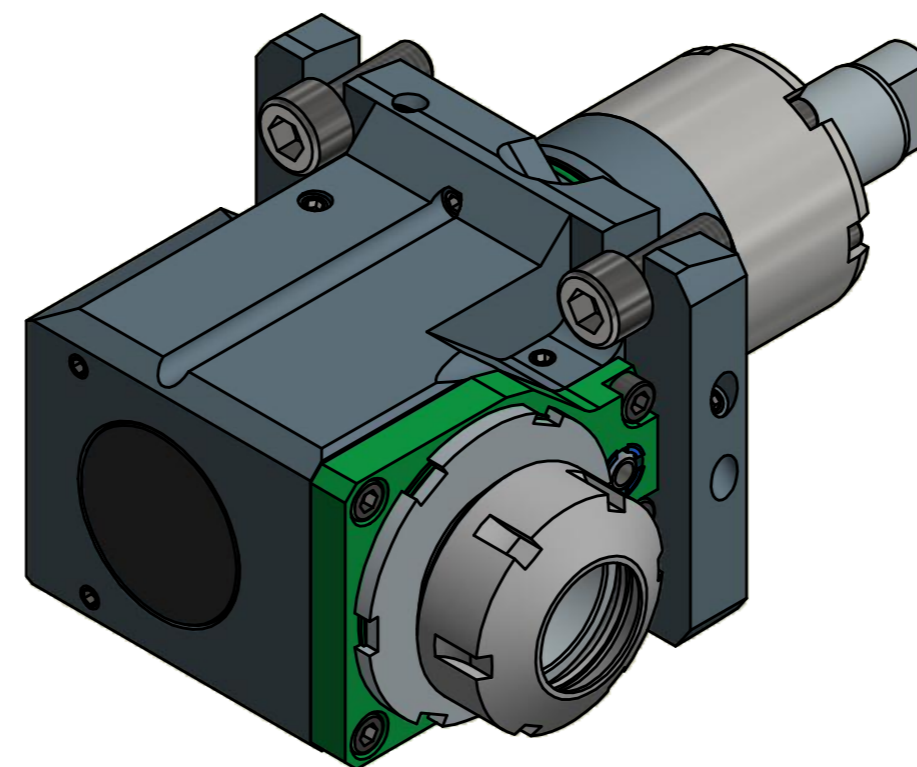
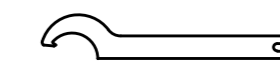

Hakenschlüssel
 mit Nase
 Hook wrench with
 nose end
 DIN1810 A 58x62

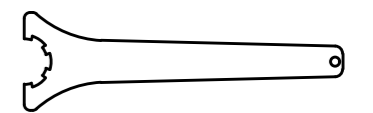

Spannzangenschlüssel
 Clamping wrench
 232

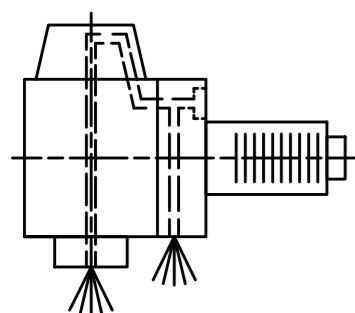

Innen- und Aussenkuehlung / Inside and outside coolant supply
 Kuehlmittelfiltrierung50μ / coolant filtration50μ

Copyright **EWS Tool Technologies**
 Weitergabe und Vervielfaeltigung dieser Unterlage,
 Verwertung und Mitteilung ihres Inhalts nicht
 gestattet, soweit nicht ausdrecklich zugestanden.
 Zuwiderhandlungen verpflichten zu Schadenersatz.

Bemerkung - Note Für Trockenlauf geeignet! Use without coolant fluid allowed! mit Kegelrollenlager with taper roller bearing(s)	Technische Daten - technical data Weight = 5,426 [kg] Torque max. (M1/M2) = 25 / 50 [Nm] Speed max. (n1/n2) = 6000 / 3000 [1/min] Gear ratio (i)=n1:n2 = 2:1 Pressure (pmax) = 70 [bar]
---	--

Benennung - Title
Radial Bohr und Fräskopf
 Radial drilling and milling head

EWS Tool Technologies <small>EWS Weigle GmbH & Co. KG Maybachstr. 1 D-73066 Ulm/ingen www.ews-tools.de</small>	Technische Aenderungen vorbehalten! Subject to technical modifications! IDENT: DEWS103942	 REV: -/C MNR. 176694
Nr. - No. 60.55.432KRLT2000V16IKDGLI2		

