

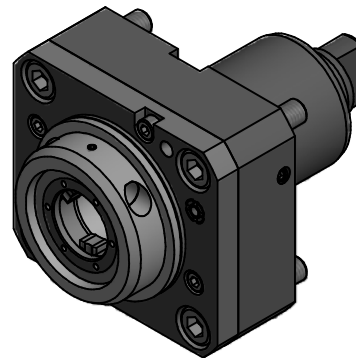

Innen- und Aussenkuehlung / Inside and outside coolant supply
 Kuehlmittelfiltrierung*50µ / coolant filtration*50µ



Copyright **EWS Tool Technologies**
 Weitergabe und Vervielfaeltigung dieser Unterlage,
 Verwertung und Mitteilung ihres Inhalts nicht
 gestattet, soweit nicht ausdrecklich zugestanden.
 Zuwiderhandlungen verpflichten zu Schadenersatz.

<p>Bemerkung - Note</p> <p>Für Trockenlauf geeignet! <i>Use without coolant fluid allowed!</i></p>	<p>Technische Daten - technical data</p> <p>Weight = 4.320 [kg] Torque max. (M1/M2) = 50 / 50 [Nm] Speed max. (n1/n2) = 6000 / 6000 [1/min] Gear ratio (i)=n1:n2 = 1:1 Pressure (pmax) = 70 [bar]</p>	<p>Benennung - Title</p> <p>Axial Bohr und Fräskopf <i>Axial drilling and milling head</i></p>	<p>EWS Tool Technologies <small>EWS Weigelt GmbH & Co. KG Maybachstr. 1 D-73066 Uhingen www.ews-tools.de</small></p>	<p>Technische Aenderungen vorbehalten! <i>Subject to technical modifications!</i></p> <p>IDENT: DEWS019628</p>	<p>REV: -/B</p> <p>MNR.</p> <p>176276</p>	<p>Nr. - No.</p> <p>40.55VX3TS4000V15IKD</p>	
---	---	--	--	---	--	---	---