

Spannzange / collet ER25 DIN6499
Spannbereich / clamping range: 1,0 - 16,0

Gewindebohrzange / tapping collet
ET-1-25 M3-M12

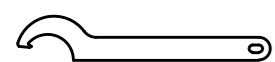

Hakenschlüssel
mit Nase
Hook wrench with
nose end
DIN1810 A 58x62

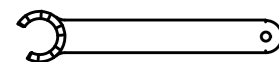

Spannzangenschlüssel für
innenliegende Mutter
Clamping wrench for
internal collet
225AX

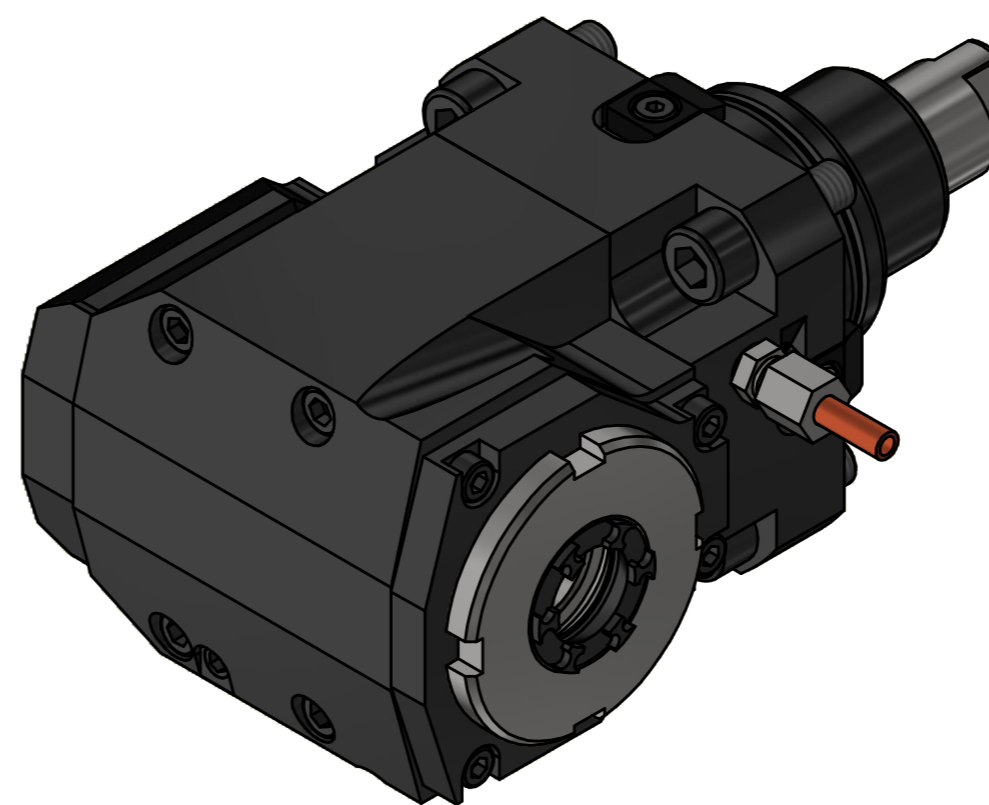

Copyright **EWS Tool Technologies**
Weitergabe und Vervielfältigung dieser Unterlage,
Verwertung und Mitteilung ihres Inhalts nicht
gestattet, soweit nicht ausdrücklich zugestanden.
Zuwendungen verpflichten zu Schadenersatz.

Bemerkung - Note mit Kegelrollenlager with taper roller bearing(s)	Technische Daten - technical data Weight = 6.713 [kg] Torque max. (M1/M2) = 40 / 80 [Nm] Speed max. (n1/n2) = 6000 / 3000 [1/min] Gear ratio (i)=n1:n2 = 2:1	Benennung - Title Radial Bohr und Fräskopf Radial drilling and milling head	 EWS Weigle GmbH & Co. KG Maybachstr. 1 D-73066 Uhlingen www.ews-tool.de	Technische Änderungen vorbehalten! Subject to technical modifications! IDENT: DEWS020850 REV: -/B MNR. 174854
--	--	---	--	---

