

Spannzange / collet ER25 DIN6499
 Spannbereich / clamping range: 1,0 - 16,0

Gewindebohrzange / tapping collet
 ET-1-25 M3-M12

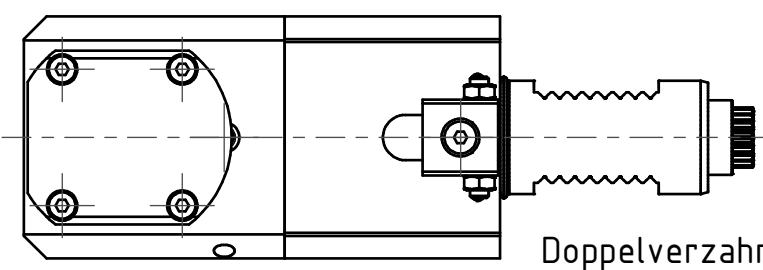

Doppelverzahnung Lizenz Traub
 double tooth system licence Traub

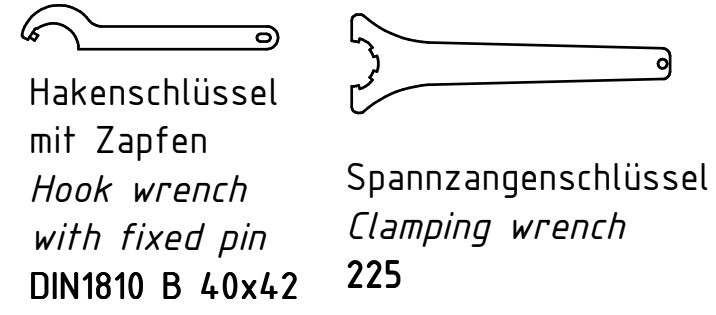

Hakenschlüssel mit Zapfen
 Hook wrench with fixed pin
 DIN1810 B 40x42

Spannzangenschlüssel
 Clamping wrench
 225

Copyright **EWS Tool Technologies**
 Weitergabe und Vervielfaeltigung dieser Unterlage,
 Verwertung und Mitteilung ihres Inhalts nicht
 gestattet, soweit nicht ausdrecklich zugestanden.
 Zuwiderhandlungen verpflichten zu Schadenersatz.

Bemerkung - Note mit Kegelrollenlager with taper roller bearing(s)	Technische Daten - technical data M1 / M2 = 25 / 25 Nm n1 / n2 = 6000 / 6000 1/min i (N1:N2) = 1:1	Benennung - Title Radial Bohr und Fräskopf Radial drilling and milling head	<table border="1"> <tr> <td>name</td> <td>date</td> </tr> <tr> <td>Theiss</td> <td>21.05.2014</td> </tr> </table>	name	date	Theiss	21.05.2014	Technische Aenderungen vorbehalten! Subject to technical modifications! Nr. 60.3025KRLCTXRL	DIN A3
name	date								
Theiss	21.05.2014								
			EWS Weigte GmbH & Co. KG Maybachstr. 1 D-73066 Uhlingen Tel. +49(0)7161/93040-100	MNR: 174787 IDENT: D-EWS-156535 A	Blatt - page 1 (1)				