

Spannzange / Collet ER16 DIN6499
 Spannbereich / Clamping range: 1,0 - 10,0

Gewindebohrzange / Tapping Collet
 ET-1-16 M1-M6

Schwenkbereich $\pm 92^\circ$
 Swivel area $\pm 92^\circ$

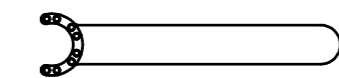
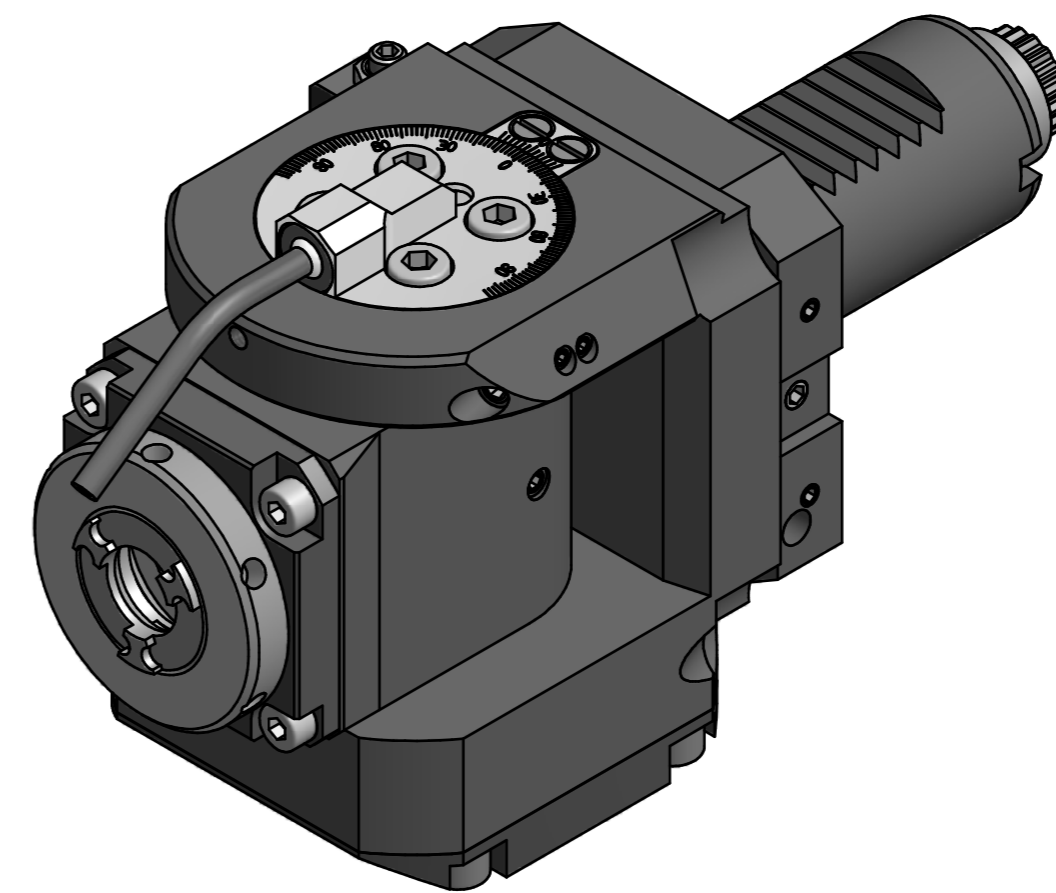
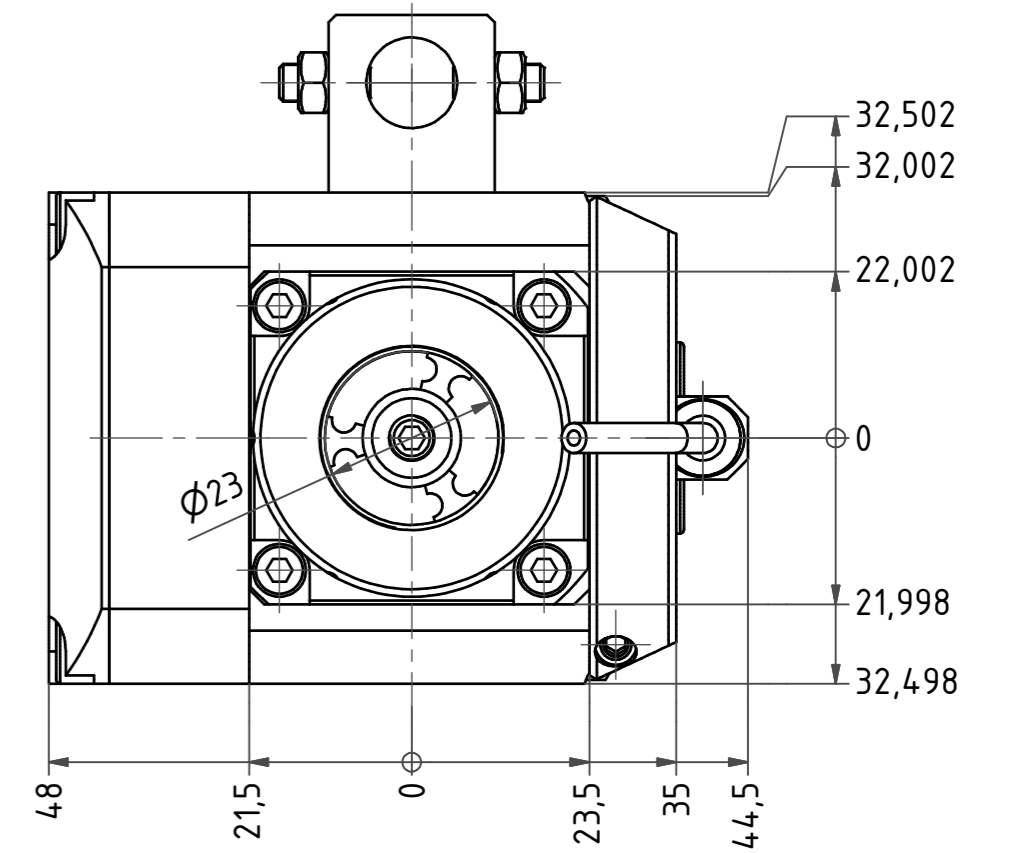
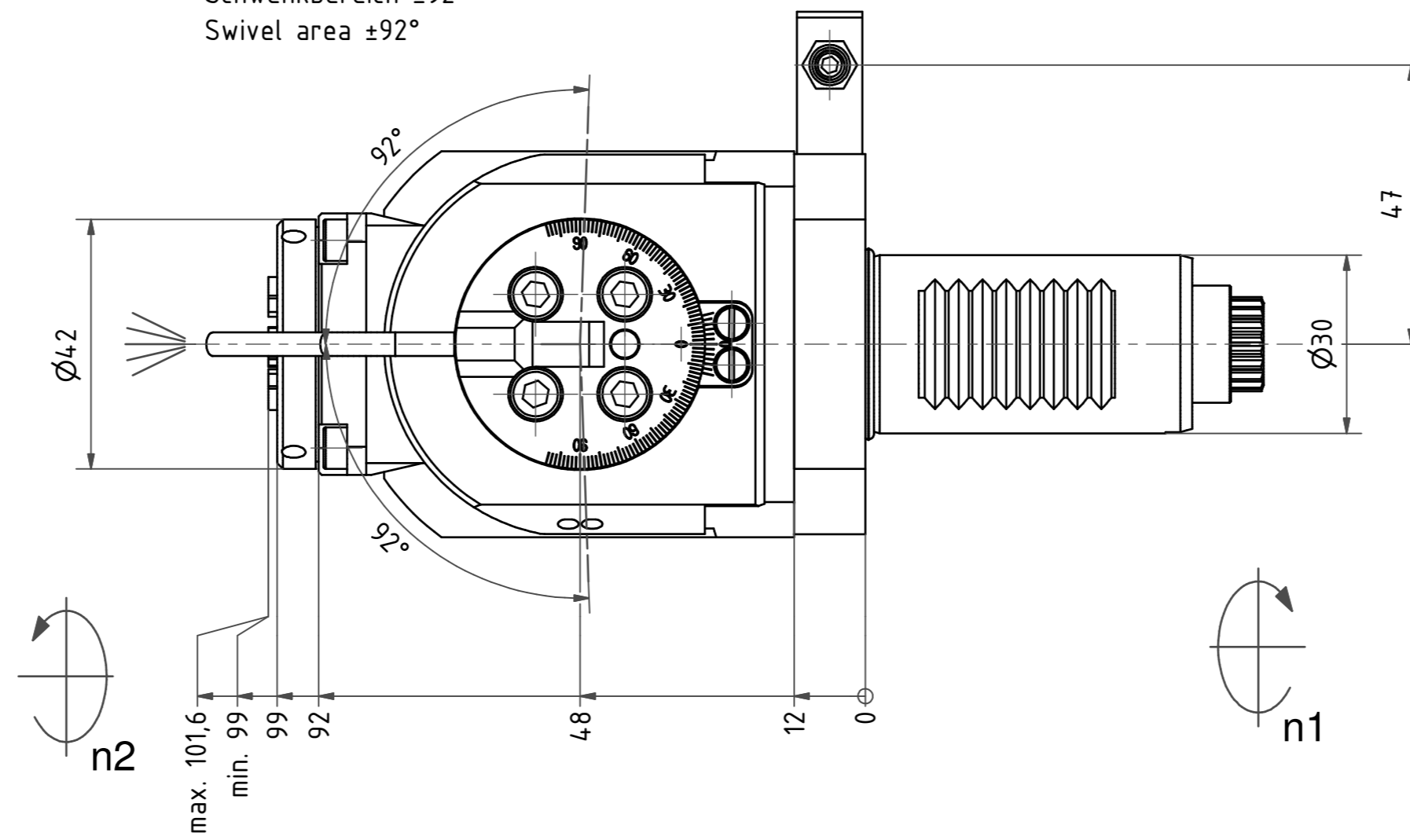

Spannzangenschlüssel für
 innenliegende Mutter
*Clamping wrench for
 internal collet*
 EA 16 K

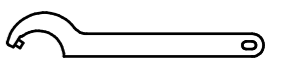

Hakenschlüssel
 mit Zapfen
*Hook wrench
 with fixed pin*
 DIN1810 B 40x42

Copyright **EWS Tool Technologies**
 Weitergabe und Vervielfältigung dieser Unterlage,
 Verwertung und Mitteilung ihres Inhalts nicht
 gestattet, soweit nicht ausdrücklich zugestanden.
 Zuwiderhandlungen verpflichten zu Schadenersatz.

| | | | | | |
|---------------------------|--|--|--|--|--|
| Bemerkung - Note | Technische Daten - Technical data | | Benennung - Title | | |
| | $M_1 / M_2 = 16 / 16 \text{ Nm}$ $n_1 / n_2 = 8000 / 8000 \text{ 1/min}$ $i (N_1:N_2) = 1:1$ | | Schwenkkopf <i>Swivel head</i> | | |
| drawing Schmid 03.07.2014 | | | name date Schmid 03.07.2014 | | Technische Änderungen vorbehalten! <i>Subject to technical modifications!</i> |
| | | | Nr. 63.3016CTXIMX48 | | |
| MNR: 176049 | | | IDENT: D-EWS-158886 A | | Blatt - page 1 (1) |