

Spannzange / collet ER32 DIN6499
Spannbereich / clamping range: 2,0 - 20,0

Gewindebohrzange / tapping collet
ET-1-32 M5-M12

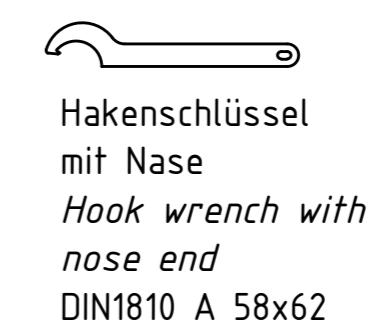
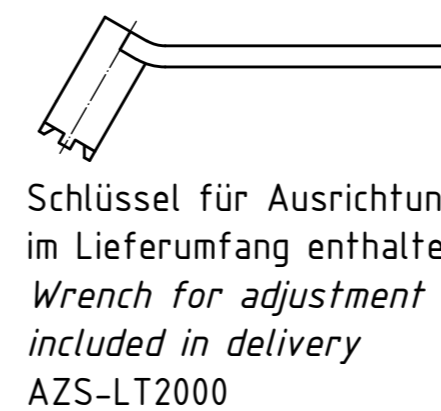
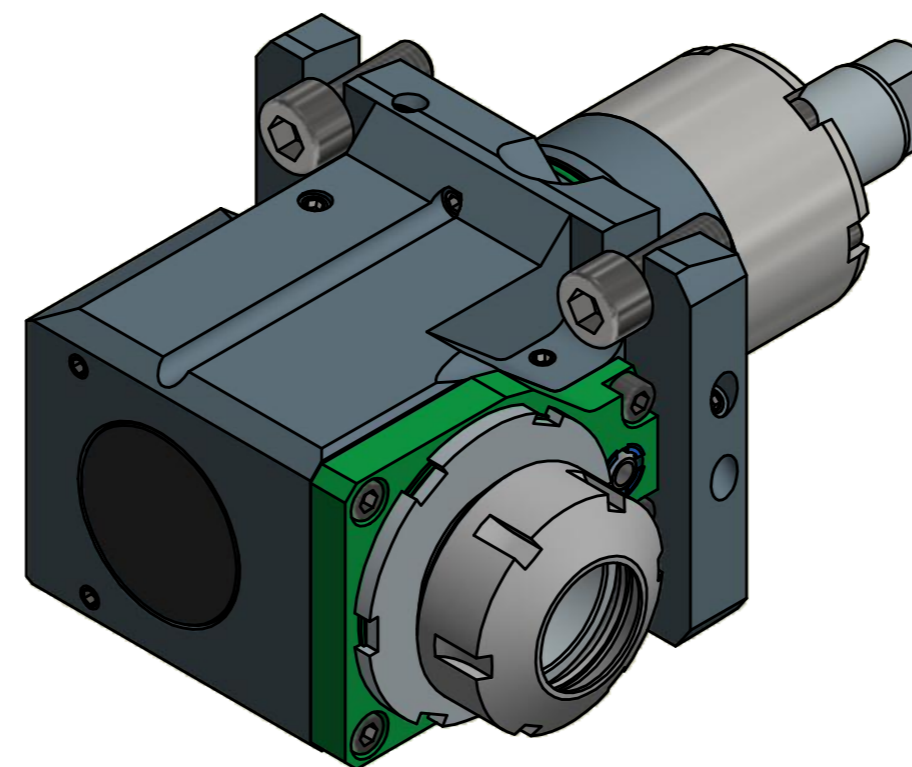

Copyright **EWS Tool Technologies**
Weitergabe und Vervielfältigung dieser Unterlage,
Verwertung und Mitteilung ihres Inhalts nicht
gestattet, soweit nicht ausdrücklich zugestanden.
Zuwerhandlungen verpflichten zu Schadenersatz.

Bemerkung - Note
mit Kegelrollenlager
with taper roller bearing(s)

Technische Daten - technical data
Weight = 5,327 [kg]
Torque max. (M1/M2) = 25 / 50 [Nm]
Speed max. (n1/n2) = 6000 / 3000 [1/min]
Gear ratio (i)=n1:n2 = 2:1

Benennung - Title
Radial Bohr und Fräskopf
Radial drilling and milling head

EWS Tool Technologies
EWS Weigle GmbH & Co. KG
Maybachstr. 1
D-73066 Uhingen
www.ews-tools.de
Technische Änderungen vorbehalten!
Subject to technical modifications!
IDENT: DEWS054161
REV: -/B
MNR.
175955

