

8 7 6 5 4 3 2 1

F
E
D
C
B
A

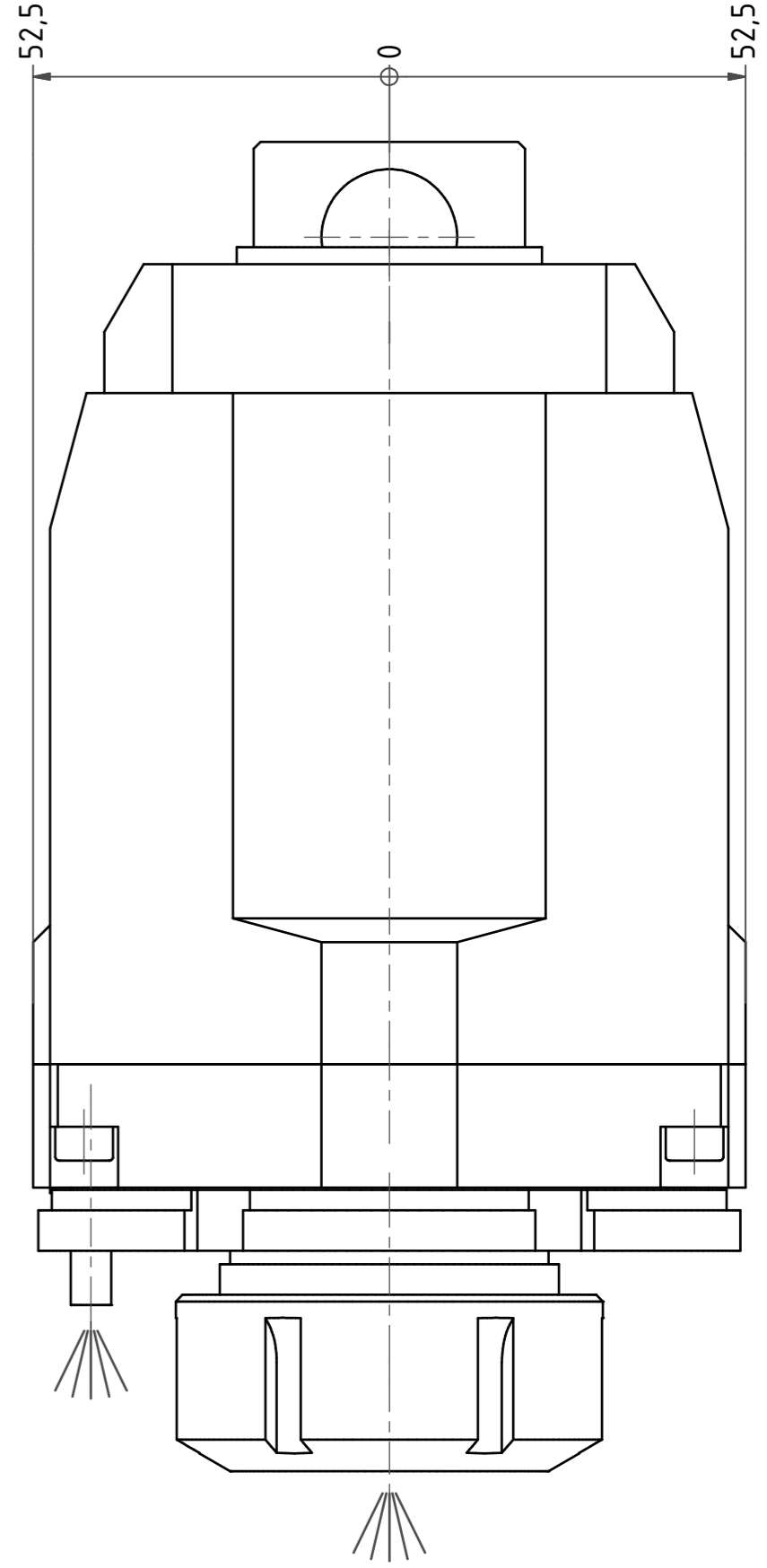

Spannzange / collet ER40 DIN6499
Spannbereich / clamping range: 3,0 - 26,0

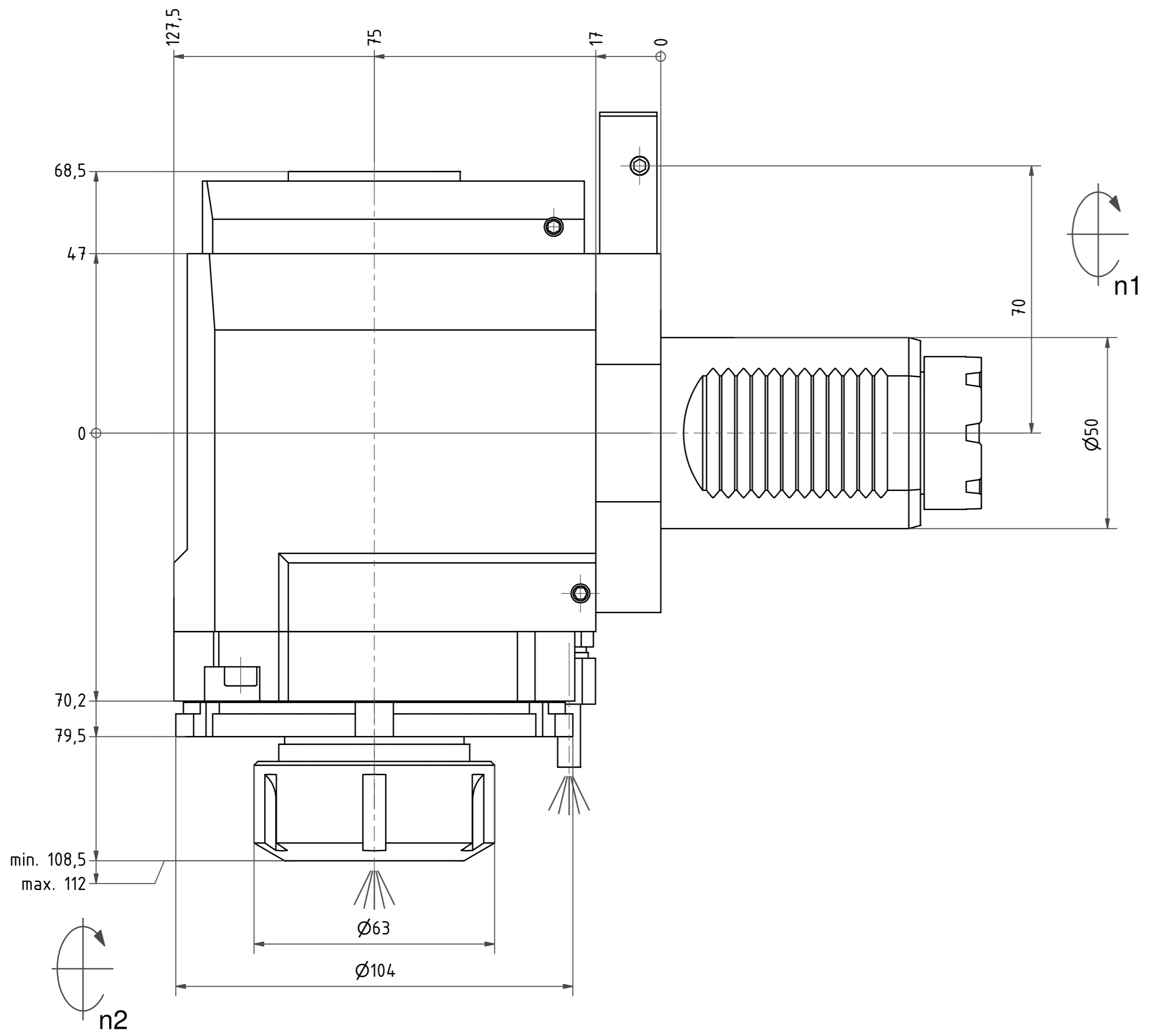
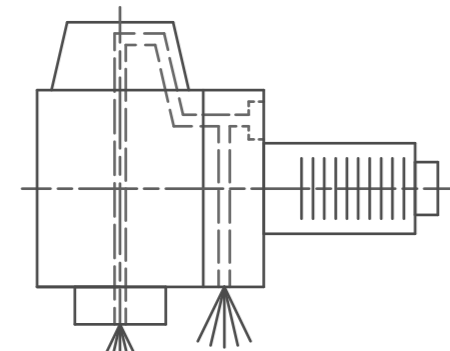

Innen- und Aussenkuehlung / Inside and outside coolant supply
Kein Trockenlauf / No dry run
Kuehlmittelfiltrierung 50μ / coolant filtration 50μ

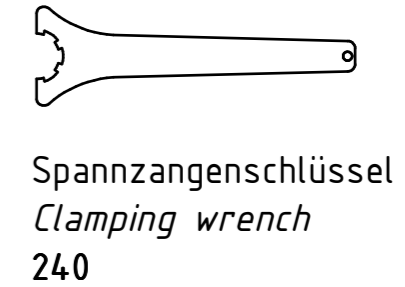
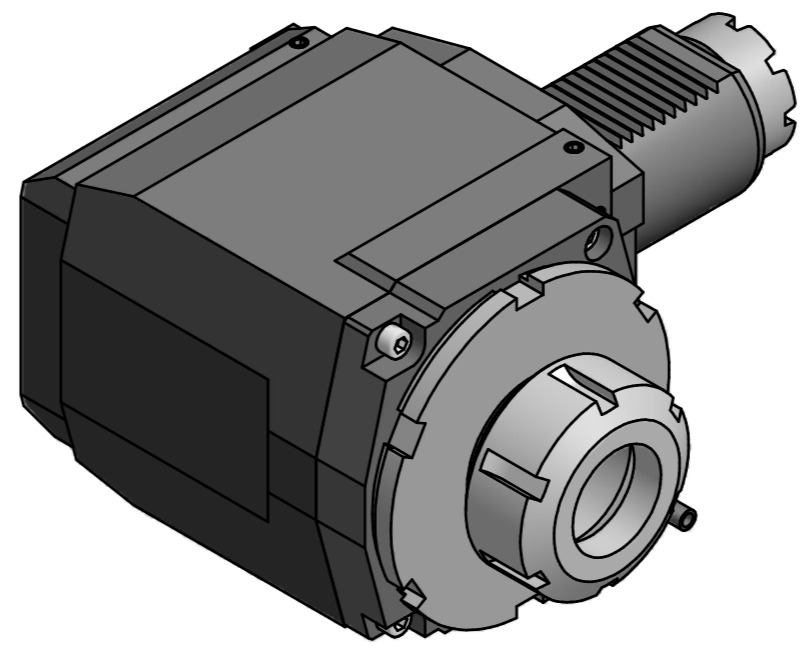

Spannzangenschlüssel
Clamping wrench
240

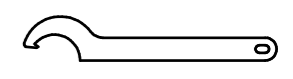

Hakenschlüssel
mit Nase
Hook wrench with
nose end
DIN1810 A 110x115

Copyright **EWS Tool Technologies**
Weitergabe und Vervielfaeltigung dieser Unterlage,
Verwertung und Mitteilung ihres Inhalts nicht
gestattet, soweit nicht ausdrecklich zugestanden.
Zuwoiderhandlungen verpflichten zu Schadenersatz.

Bemerkung - Note Nicht ohne Kuehlmittel betreiben! Not for use without coolant-fluid! mit Kegelrollenlager with taper roller bearing(s)		Technische Daten - Technical data M1 / M2 = 80 / 160 Nm n1 / n2 = 4000 / 2000 1/min i (N1:N2) = 2:1 Pmax = 70 bar		Benennung - Title Radial Bohr und Fräskopf Radial drilling and milling head		<table border="1"> <tr> <th>name</th> <th>date</th> <th>Technische Aenderungen vorbehalten!</th> </tr> <tr> <td>Theiss</td> <td>25.06.2014</td> <td>Subject to technical modifications!</td> </tr> <tr> <td colspan="3"> Nr. 60.5040KRTOEMRIKI2GL EWS Weigelt GmbH & Co. KG Maybachstr. 1 D-73066 Uffingen Tel. +49(0)716193040-100 MNR: 175489 IDENT: D-EWS-158439 - Blatt - page 1 (1) </td> </tr> </table>		name	date	Technische Aenderungen vorbehalten!	Theiss	25.06.2014	Subject to technical modifications!	Nr. 60.5040KRTOEMRIKI2GL EWS Weigelt GmbH & Co. KG Maybachstr. 1 D-73066 Uffingen Tel. +49(0)716193040-100 MNR: 175489 IDENT: D-EWS-158439 - Blatt - page 1 (1)		
name	date	Technische Aenderungen vorbehalten!														
Theiss	25.06.2014	Subject to technical modifications!														
Nr. 60.5040KRTOEMRIKI2GL EWS Weigelt GmbH & Co. KG Maybachstr. 1 D-73066 Uffingen Tel. +49(0)716193040-100 MNR: 175489 IDENT: D-EWS-158439 - Blatt - page 1 (1)																

8 7 6 5 4 3 2 1