

8 7 6 5 4 3 2 1

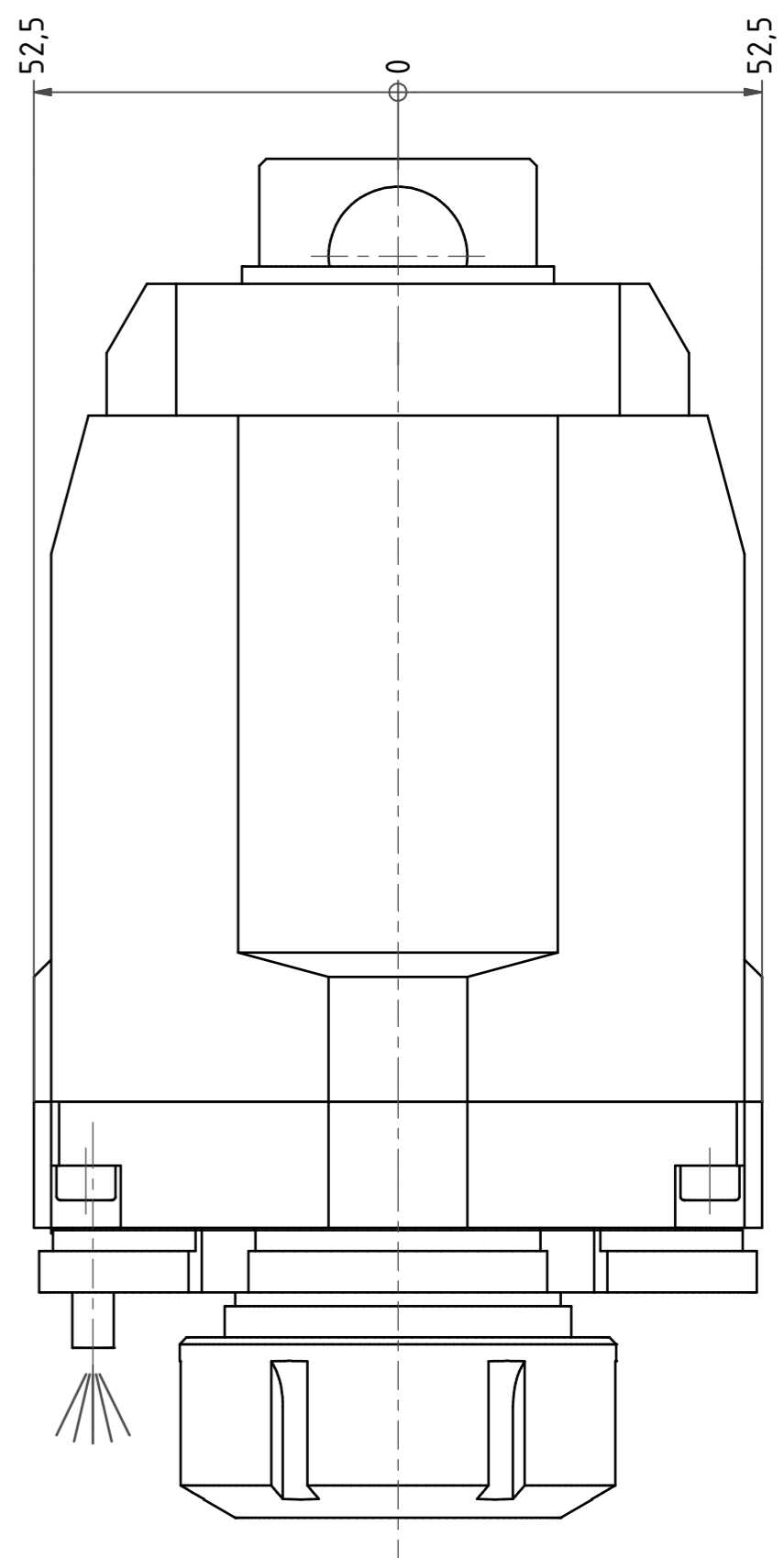

Spannzange / collet ER40 DIN6499
 Spannungsbereich / clamping range: 3,0 - 26,0

Gewindebohrzange / tapping collet
 ET-1-40 M6-M16

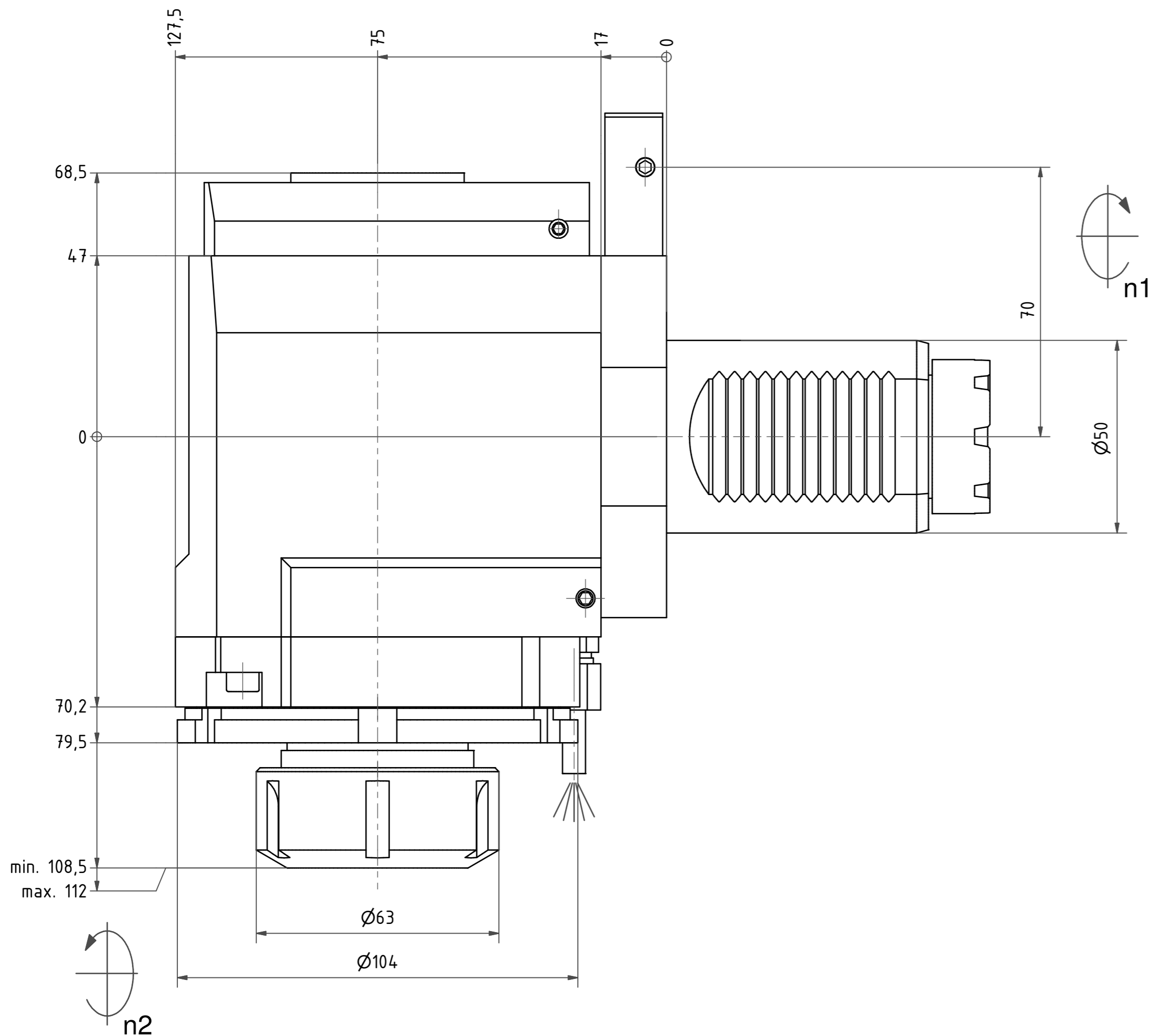
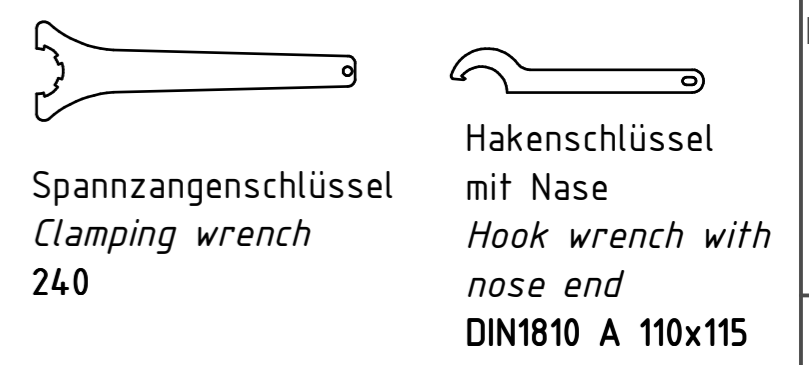
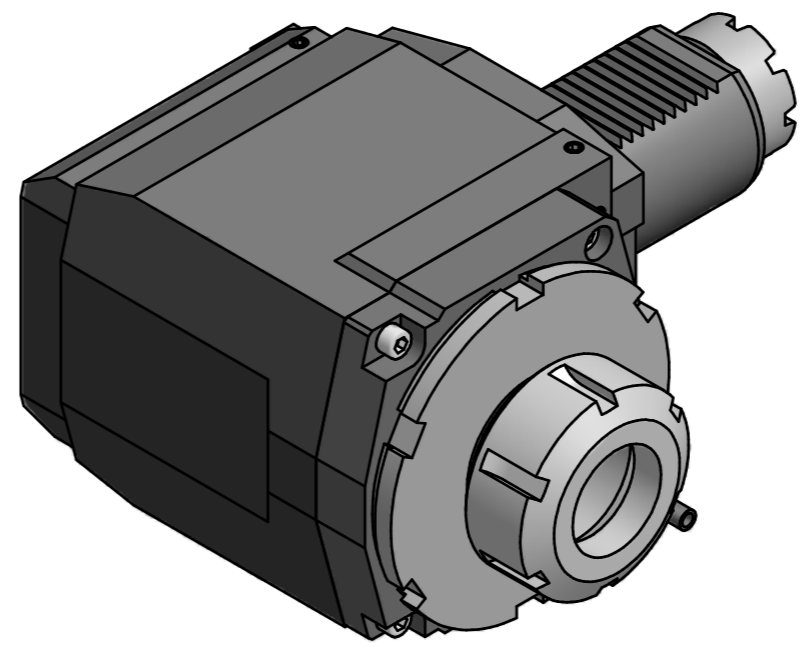

Copyright **EWS Tool Technologies**
 Weitergabe und Vervielfältigung dieser Unterlage,
 Verwertung und Mitteilung ihres Inhalts nicht
 gestattet, soweit nicht ausdrücklich zugestanden.
 Zuwiderhandlungen verpflichten zu Schadenersatz.

Bemerkung - Note mit Kegelrollenlager with taper roller bearing(s)	Technische Daten - Technical data M ₁ / M ₂ = 80 / 160 Nm n ₁ / n ₂ = 4000 / 2000 1/min i (N ₁ :N ₂) = 2:1	Benennung - Title Radial Bohr und Fräskopf Radial drilling and milling head	name	date	Technische Änderungen vorbehalten! Subject to technical modifications!
			drawing	Theiss	
			EWS EWS Weigete GmbH & Co. KG Maybachstr. 1 D-72096 Ulm/lingen Tel. +49(0)7161/93040-100		Nr. 60.5040KRTOEMRI2
			MNR: 175487		IDENT: D-EWS-158436 - Blatt - page 1 (1)

8 7 6 5 4 3 2 1