

Spannzange / collet ER32 DIN6499
 Spannbereich / clamping range: 2,0 - 20,0

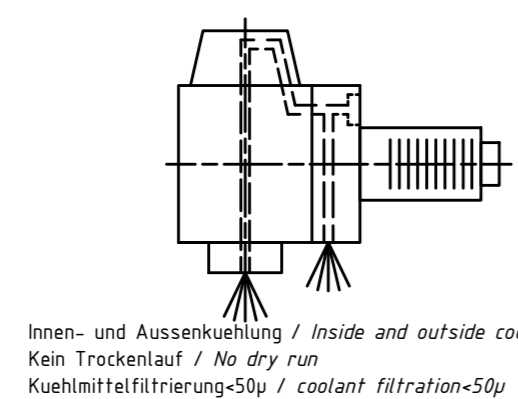

Innen- und Aussenkuehlung / Inside and outside coolant supply
 Kein Trockentlauf / No dry run
 Kuehlmittelfiltrierung-50µ / coolant filtration-50µ

 Hakenschlüssel
 mit Nase
 Hook wrench with
 nose end
 DIN1810 A 80x90

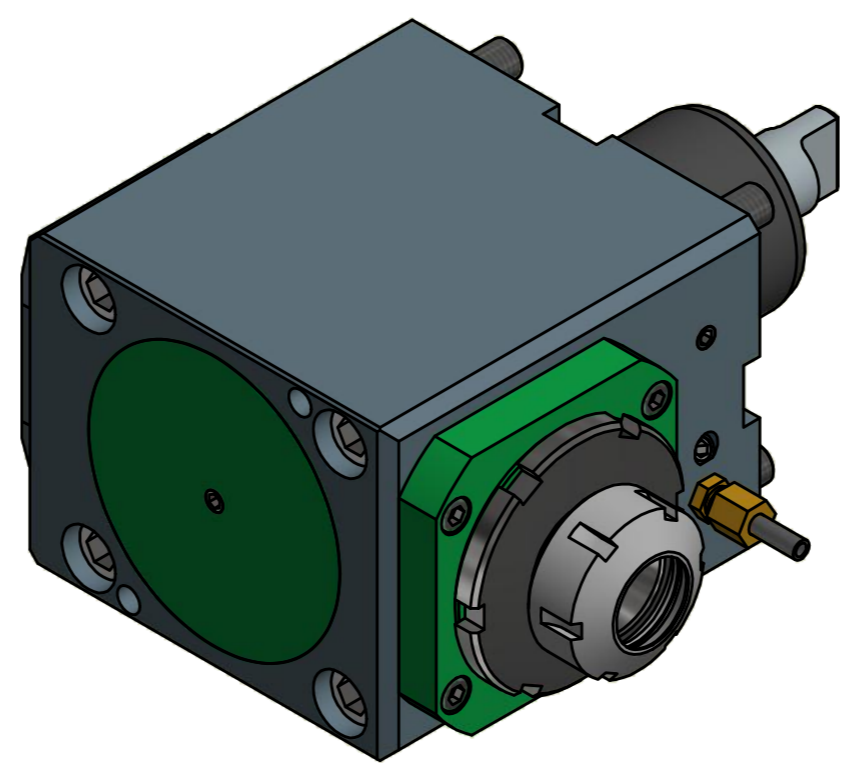
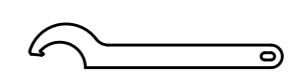

 Spannzangenschlüssel
 Clamping wrench
 232

Copyright **EWS Tool Technologies**
 Weitergabe und Vervielfaeltigung dieser Unterlage,
 Verwertung und Mitteilung ihres Inhalts nicht
 gestattet, soweit nicht ausdruercklich zugestanden.
 Zuwiderhandlungen verpflichten zu Schadenersatz.

Bemerkung - Note Nicht ohne Kuehlmittel betreiben! Not for use without coolant-fluid!	Technische Daten - technical data Weight = 15,059 [kg]
	Torque max. (M1/M2) = 100 / 100 [Nm]
	Speed max. (n1/n2) = 10000 / 10000 [1/min]
	Gear ratio (i)=n1:n2 = 1:1
	Pressure (pmax) = 70 [bar]

Benennung - Title
Radial Bohr und Fräskopf
 Radial drilling and milling head

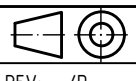
EWS Tool Technologies <small>EWS Weigle GmbH & Co. KG Maybachstr. 1 D-73066 Uhlingen www.ews-tool.de</small>	Technische Aenderungen vorbehalten! Subject to technical modifications! IDENT: DEWS054246
	Nr. - No. 60.6032NLIKHS10

 REV: -/D
 MNR.
 173648
QR