

Spannzange / collet ER32 DIN6499  
Spannbereich / clamping range: 2,0 - 20,0

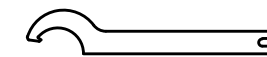

Hakenschlüssel  
mit Nase  
Hook wrench with  
nose end  
DIN1810 A 80x90

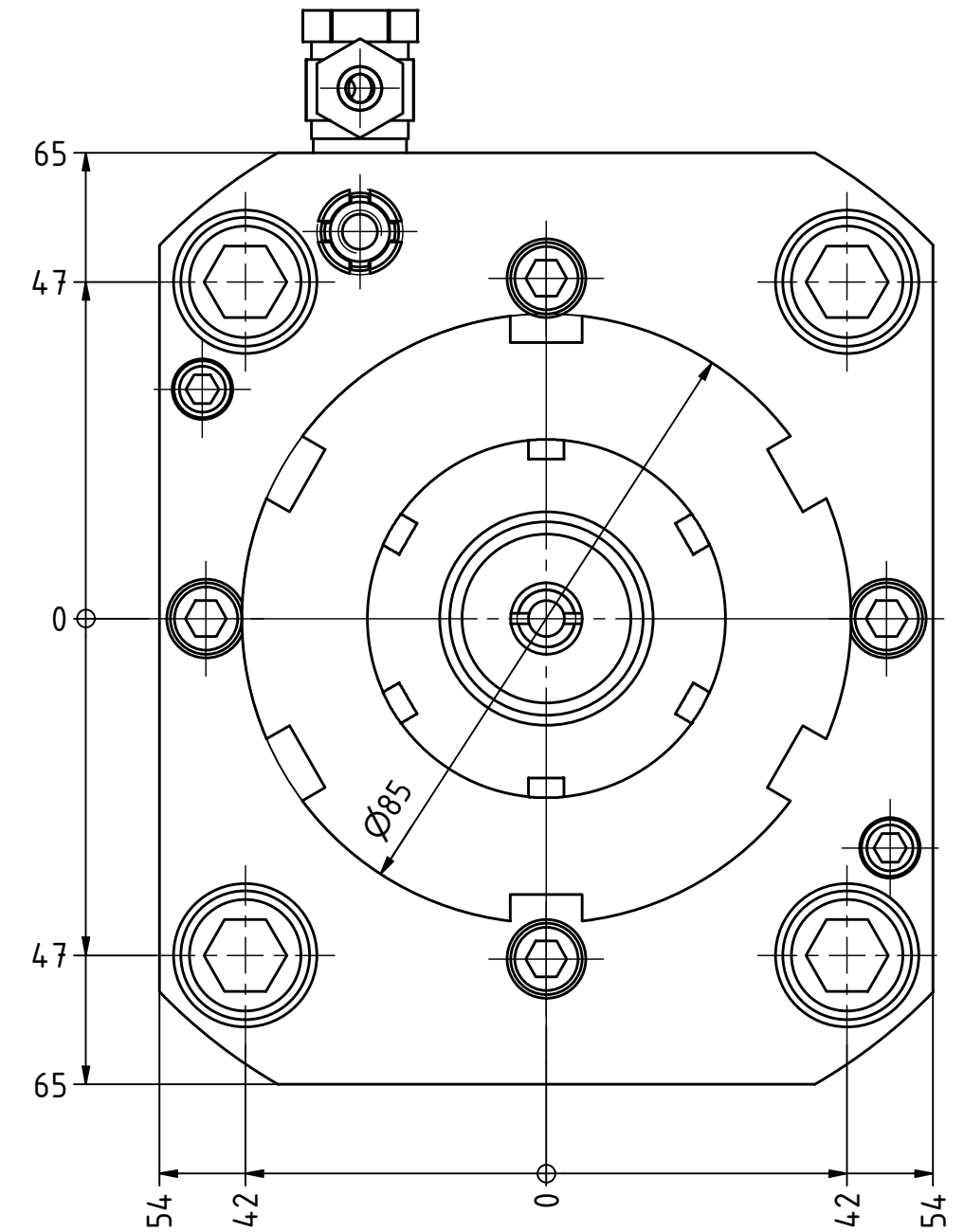
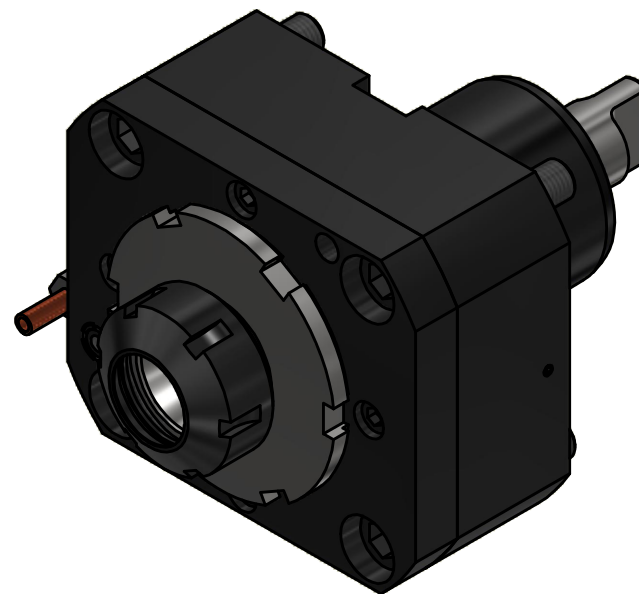
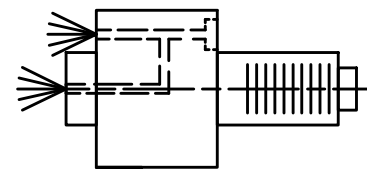

Spannzangenschlüssel  
Clamping wrench  
232

Innen- und Aussenkuehlung / Inside and outside coolant supply  
Kuehlmittelfiltrierung <math>50\mu</math> / coolant filtration <math>50\mu</math>

Copyright **EWS Tool Technologies**  
Weitergabe und Vervielfaeltigung dieser Unterlage,  
Verwertung und Mitteilung ihres Inhalts nicht  
gestattet, soweit nicht ausdrecklich zugestanden.  
Zuwiderhandlungen verpflichten zu Schadenersatz.

Bemerkung - Note  
Für Trockenlauf geeignet!  
Use without coolant fluid allowed!

Technische Daten - technical data  
Weight = 9.503 [kg]  
Torque max. (M1/M2) = 100 / 100 [Nm]  
Speed max. (n1/n2) = 10000 / 10000 [1/min]  
Gear ratio (i)=n1:n2 = 1:1  
Pressure (pmax) = 70 [bar]

Benennung - Title  
**Axial Bohr und Fräskopf**  
**Axial drilling and milling head**

**EWS** Tool Technologies  
EWS Weigle GmbH & Co. KG  
Maybachstr. 1  
D-73066 Utingen  
www.ews-tools.de

Technische Aenderungen vorbehalten!  
Subject to technical modifications!

IDENT: DEWS150357

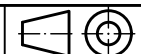

REV: -/E

Nr. - No.

40.6032NLIKDHSD10

MNR.

173645

**QR**