

Spannzange / collet ER40 DIN6499
Spannbereich / clamping range: 3,0 - 26,0

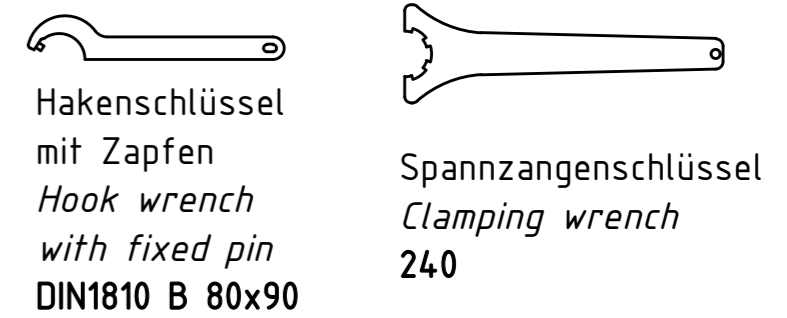
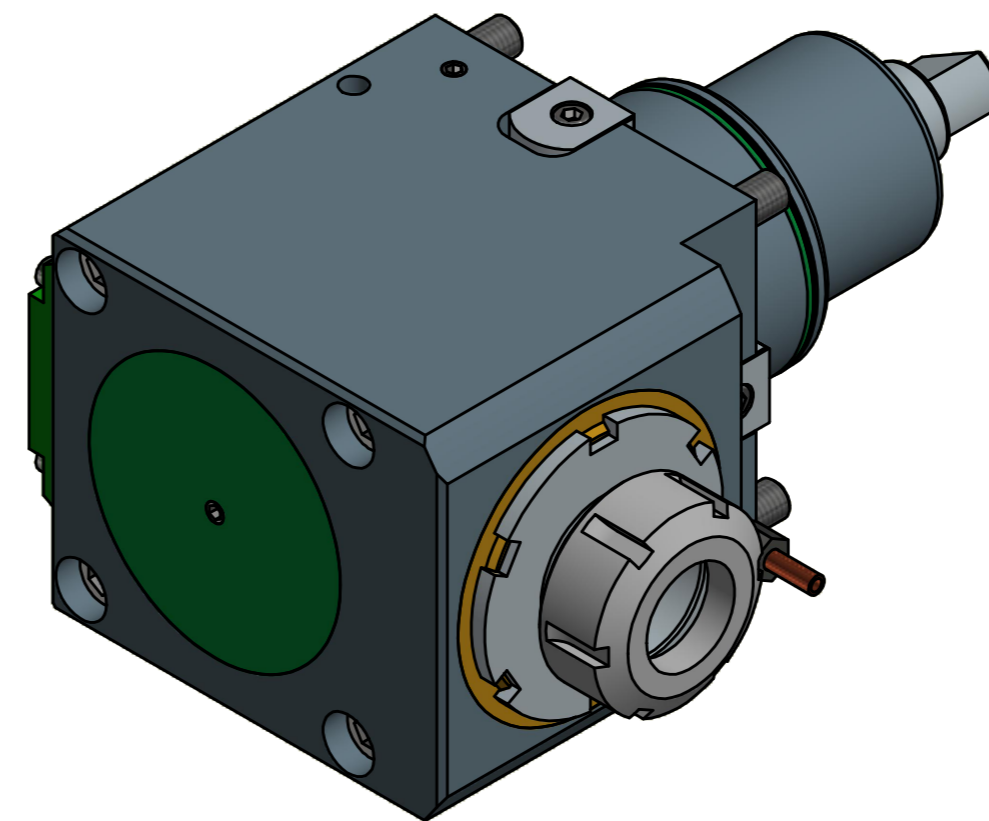

Copyright **EWS Tool Technologies**
Weitergabe und Vervielfältigung dieser Unterlage, Verwertung und Mitteilung ihres Inhalts nicht gestattet, soweit nicht ausdrücklich zugestanden. Zuwiderhandlungen verpflichten zu Schadenersatz.

Innen- und Aussenkuehlung / Inside and outside coolant supply
Kein Trockenlauf / No dry run
Kuehlmittelfiltrierung+50µ / coolant filtration+50µ

<p>Bemerkung - Note Nicht ohne Kuehlmittel betreiben! Not for use without coolant-fluid!</p>	<p>Technische Daten - technical data Weight = 20.118 [kg] Torque max. (M1/M2) = 100 / 100 [Nm] Speed max. (n1/n2) = 4000 / 4000 [1/min] Gear ratio (i)=n1:n2 = 1:1 Pressure (pmax) = 70 [bar]</p>	<p>Benennung - Title Radial Bohr und Fräskopf Radial drilling and milling head</p>	<p>EWS Tool Technologies EWS Weigle GmbH & Co. KG Maybachstr. 1 D-73066 Uhlingen www.ews-tool.de</p>	<p>Technische Aenderungen vorbehalten! Subject to technical modifications! IDENT: DEWS132903 REV: -/B</p>	<p>Nr. - No. 60.854.01809IKGLX85 MNR. 173531</p>
------------------------------------------------------------------------------------------------------	-----------------------------------------------------------------------------------------------------------------------------------------------------------------------------------------------------------------------	----------------------------------------------------------------------------------------------------------	---------------------------------------------------------------------------------------------------------------------------------	-----------------------------------------------------------------------------------------------------------------------	----------------------------------------------------------------------------

