

Spannzange / collet ER25 DIN6499
Spannbereich / clamping range: 1,0 - 16,0

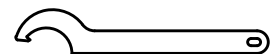

Hakenschlüssel
mit Nase
Hook wrench with
nose end
DIN1810 A 45x50

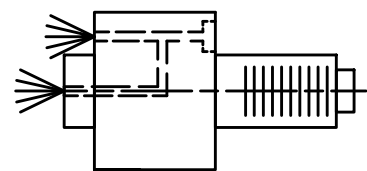
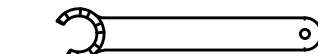

Spannzangenschlüssel für
innenliegende Mutter
Clamping wrench for
internal collet
225AX

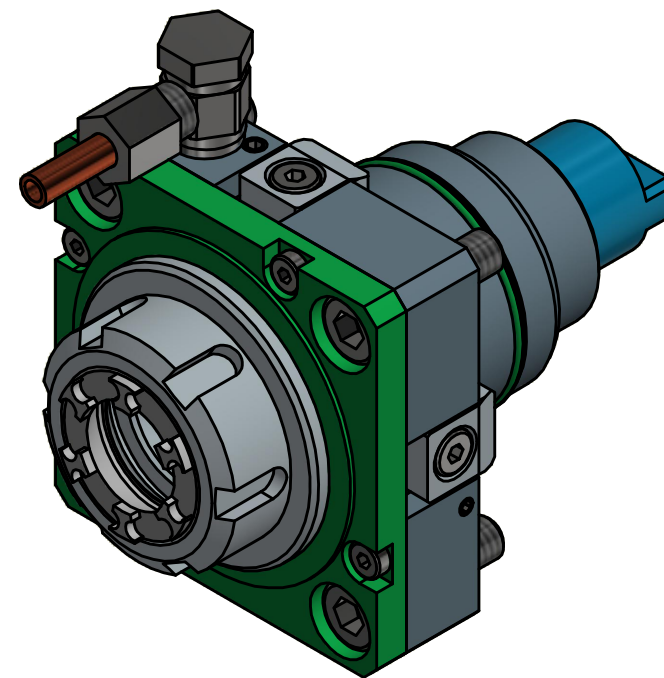

Copyright **EWS Tool Technologies**
Weitergabe und Vervielfältigung dieser Unterlage,
Verwertung und Mitteilung ihres Inhalts nicht
gestattet, soweit nicht ausdrücklich zugestanden.
Zu widerhandlungen verpflichten zu Schadenersatz.

Innen- und Aussenkuehlung / Inside and outside coolant supply
Kein Trockenlauf / No dry run
Kuehlmittelfiltrierung 50μ / coolant filtration 50μ

Bemerkung - Note
Nicht ohne Kuehlmittel betreiben!
Not for use without coolant-fluid!

Technische Daten - technical data
Weight = 1.643 [kg]
Torque max. (M1/M2) = 36 / 36 [Nm]
Speed max. (n1/n2) = 6000 / 6000 [1/min]
Gear ratio (i)=n1:n2 = 1:1
Pressure (pmax) = 25 [bar]

Benennung - Title
Axial Bohr und Fräskopf
Axial drilling and milling head

EWS
Tool Technologies
EWS Weigle GmbH & Co. KG
Maybachstr. 1
D-73066 Utingen
www.ews-tools.de

Technische Aenderungen vorbehalten!
Subject to technical modifications!

IDENT: DEWS020413



REV: -/A

Nr. - No.
40.4525TC600IKIM

MNR.
172036

QR