

60
64,5
74
min. 74
max. 75,9

Ø45
Ø56

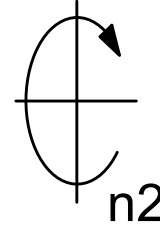

Spannzange / collet ER25 DIN6499
Spannbereich / clamping range: 1,0 - 16,0

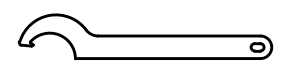
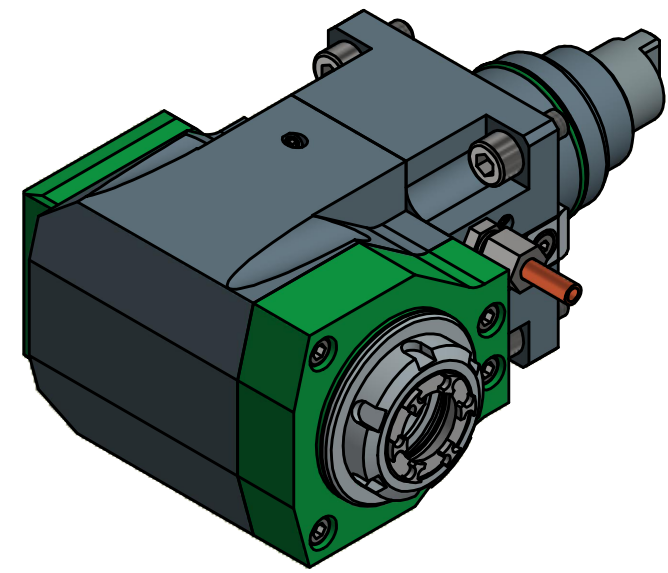

Hakenschlüssel
mit Nase
Hook wrench with
nose end
DIN1810 A 45x50

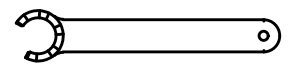

Spannzangenschlüssel für
innenliegende Mutter
Clamping wrench for
internal collet
225AX

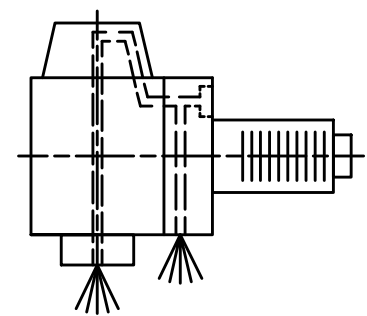

Innen- und Aussenkuehlung / Inside and outside coolant supply
Kuehlmittelfiltrierung <math>< 50\mu</math> / coolant filtration <math>< 50\mu</math>

Copyright **EWS Tool Technologies**
Weitergabe und Vervielfaeltigung dieser Unterlage,
Verwertung und Mitteilung ihres Inhalts nicht
gestattet, soweit nicht ausdrecklich zugestanden.
Zuwiderhandlungen verpflichten zu Schadenersatz.

Bemerkung - Note
Für Trockenlauf geeignet!
Use without coolant fluid allowed!

Technische Daten - technical data
Weight = 5.649 [kg]
Torque max. (M1/M2) = 50 / 50 [Nm]
Speed max. (n1/n2) = 6000 / 6000 [1/min]
Gear ratio (i)=n1:n2 = 1:1
Pressure (pmax) = 70 [bar]

Benennung - Title
Radial Bohr und Fräskopf
Radial drilling and milling head

EWS Tool Technologies
EWS Weigle GmbH & Co. KG
Maybachstr. 1
D-73066 UHINGEN
www.ews-tools.de

Technische Aenderungen vorbehalten!
Subject to technical modifications!
IDENT: DEWS007961
MNR.

REV: -/A
172033



Nr. - No.
60.4525TC600IKDGLIMX85